



## Designing Battery Charger using GAIA Converter 150W or 200W DC/DC Converter

- Easy schematics to design battery charger

### 1- Subject

A battery charger is a device used to put energy into a battery by forcing an electric current through it. The charge current depends upon the technology and capacity of the battery being charged. There are 4 main battery technology types:

- Lead Acid battery
- Nickel Cadmium (NiCad) battery
- Nickel Metal Hybrid (NiMH) battery
- Lithium (Li-Ion or Li-Poly) battery

Old battery technology requires simple charging system with constant current while many new battery technologies (NiCad, NiMH, and Lithium) require sophisticated charging and monitoring systems to preserve their high performance and to extend their life. So basically there are 2 types of battery chargers:

- Simple charger
- Advanced charger

A simple charger works by connecting a constant DC power source to the battery.

An advanced charger can monitor different battery parameters such as voltage, temperature, time under charge, overvoltage, ... to determine the optimum charge current.

### 2- Designing a Battery Charger with DC/DC converter

DC/DC converter used as bulk power element can regulate the output current and provide optimized battery charger solutions with very high efficiency and small size.

GAIA Converter describes in this application note different solutions to design battery chargers with its range of 150W or 200W DC/DC converters : the two families MGDM-150 and MGDM-200 starting from 3.3V to 24V output.

The MGDM-150 or MGDM-200 families of modules enable designers to easily build battery charging system using standard available parts. With its wide range of outputs from 3.3V up to 24Vdc, the MGDM-150 and MGDM-200 series offer designers a simple, cost-effective solution to battery charging for all major battery types.

The MGDM-150, MGDM-200 modules provide an output current monitoring signal (Share) and very large voltage outputs trimming range and ideal for applications involving standard input and output voltages.

The MGDM-150 and MGDM-200 series allow also setting independently the output voltage and the charge current.

6

## 3- Designing a Basic Battery Charger

### 3-1 Setting the battery voltage :

The battery voltage can be set by using the "Trim" function as it is recommended in the datasheet.

### 3-2 Setting the charge current :

The two figures hereunder show a basic charging circuit with a single MGDM-150 or MGDM-200 module providing a nominal output voltage corresponding to the voltage of the battery charged.

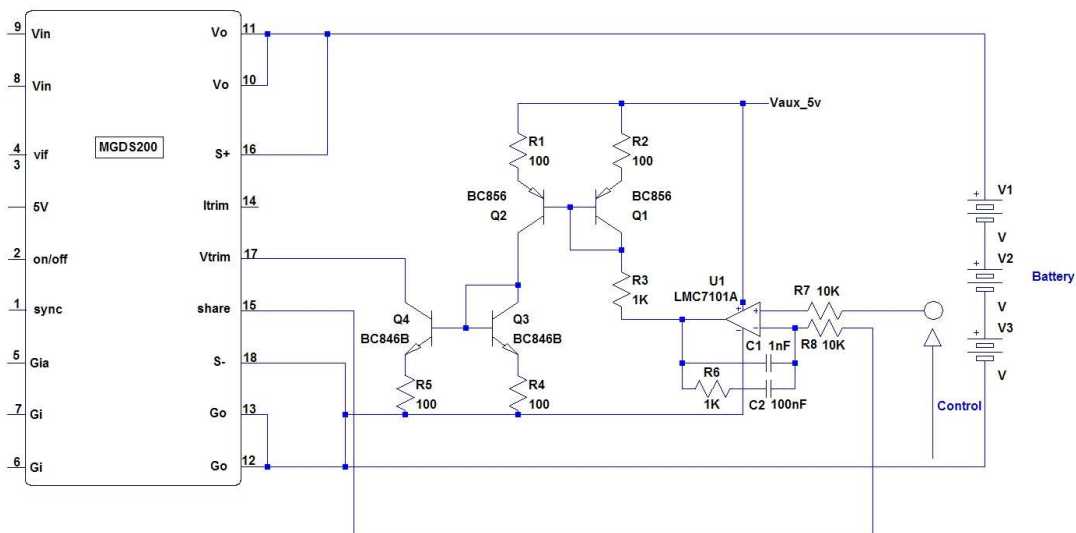
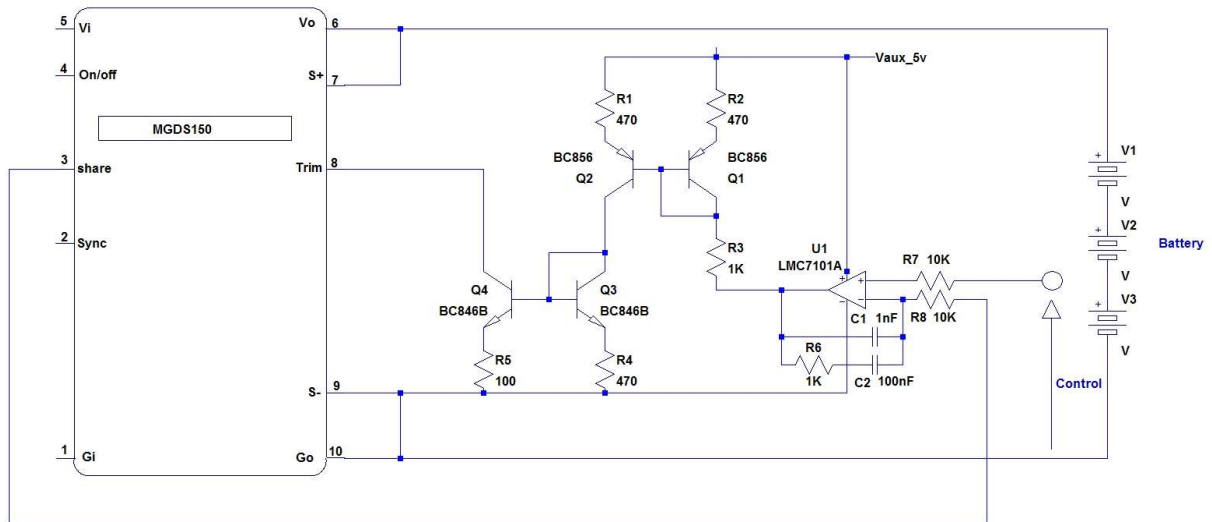

## 3-2 Setting the charge current (continued) :

The charge current can be programmed from 0 to maximum ( $I_{o_{nom}}$ ) by applying a «Control» voltage from 0 to maximum 3V. To determine the «Control» voltage required to produce a particular charge current, use the typical curve given in figures herafter. It gives the relation between the output current monitoring voltage «Share» and the output current.

Voltage Vshare on 150W Module as a function of % of Output Current

■ Vshare Typ.      — Vshare Max      ▲ Vshare min

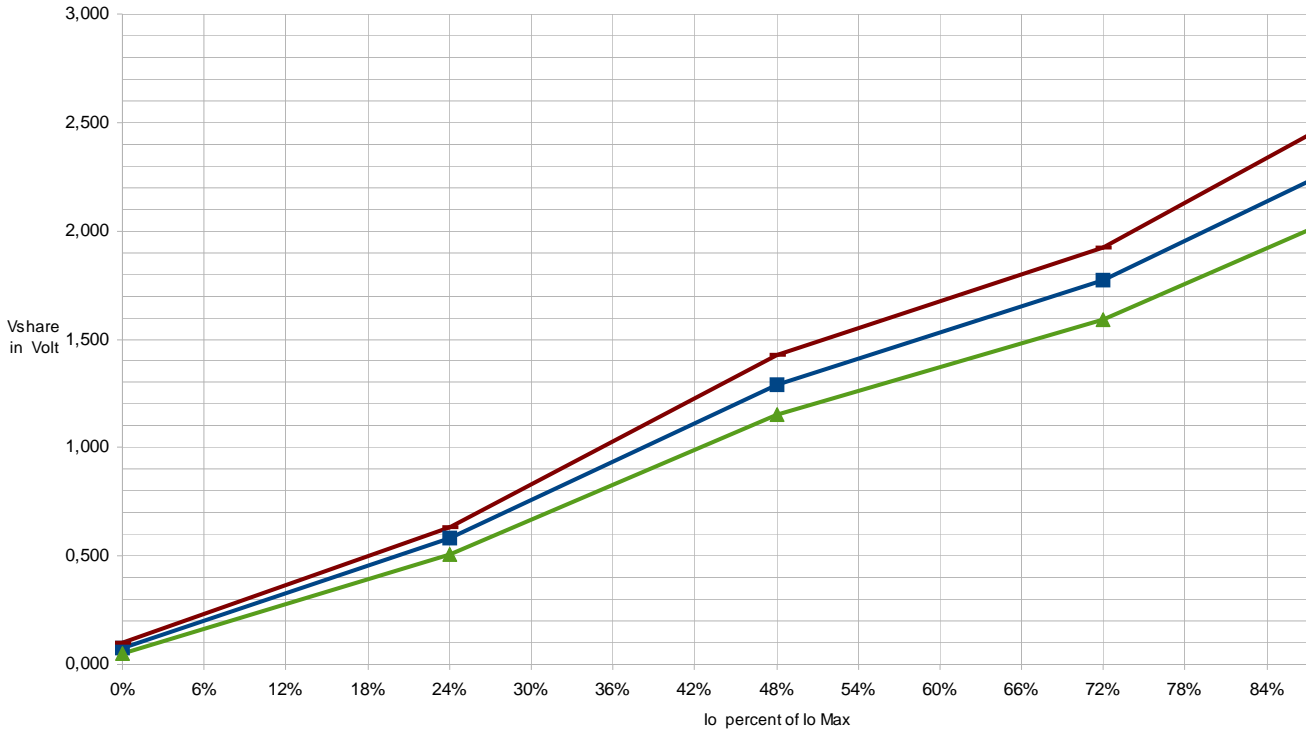

Voltage Vshare on 200W Module as a function of % of Output Current

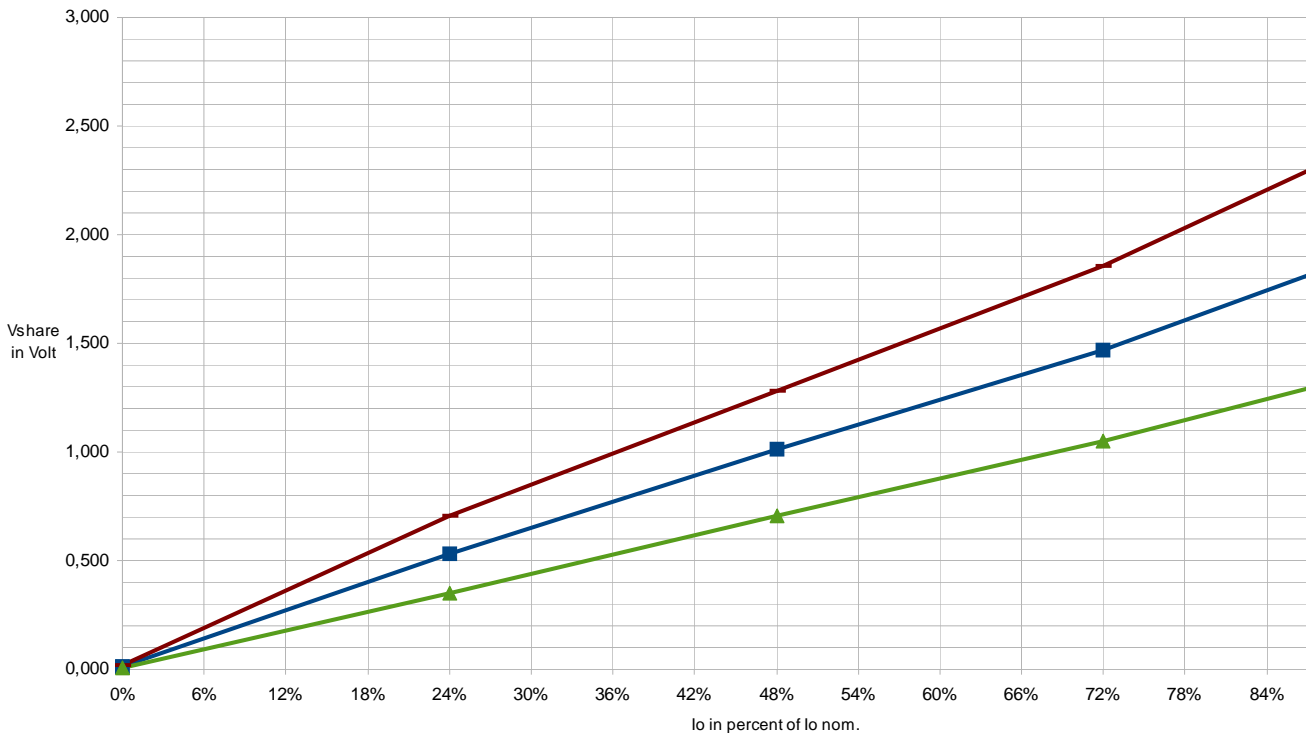

## 3- High Power Battery Charger

The MGDM-150 or MGDM-200 series offer the possibility to easily build high power battery charging system able to deliver more than 200W by parallelized several converters.

Figure below shows the circuit required to control the charge current with "n" modules.

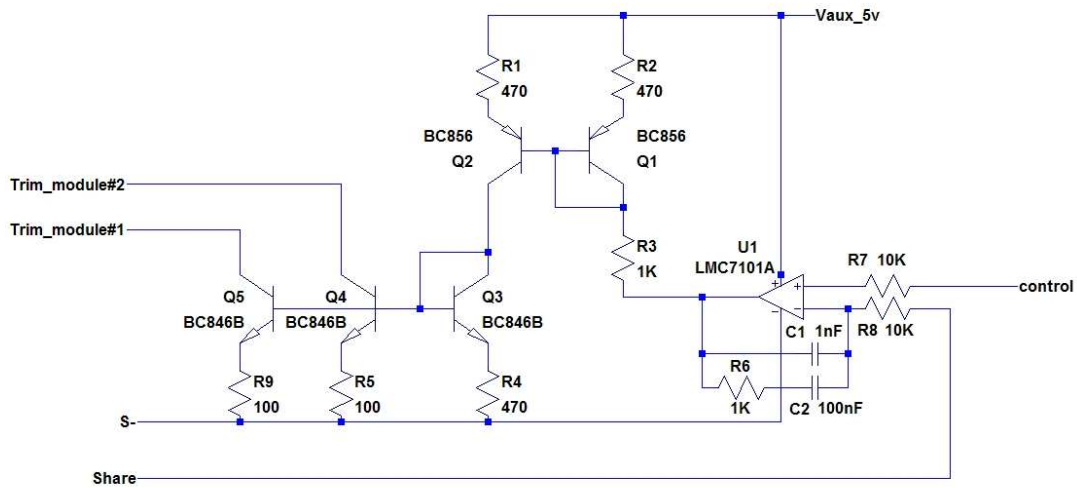

The example below depicts an application using 2xMGDM-200 converters to form a 400W battery charger.

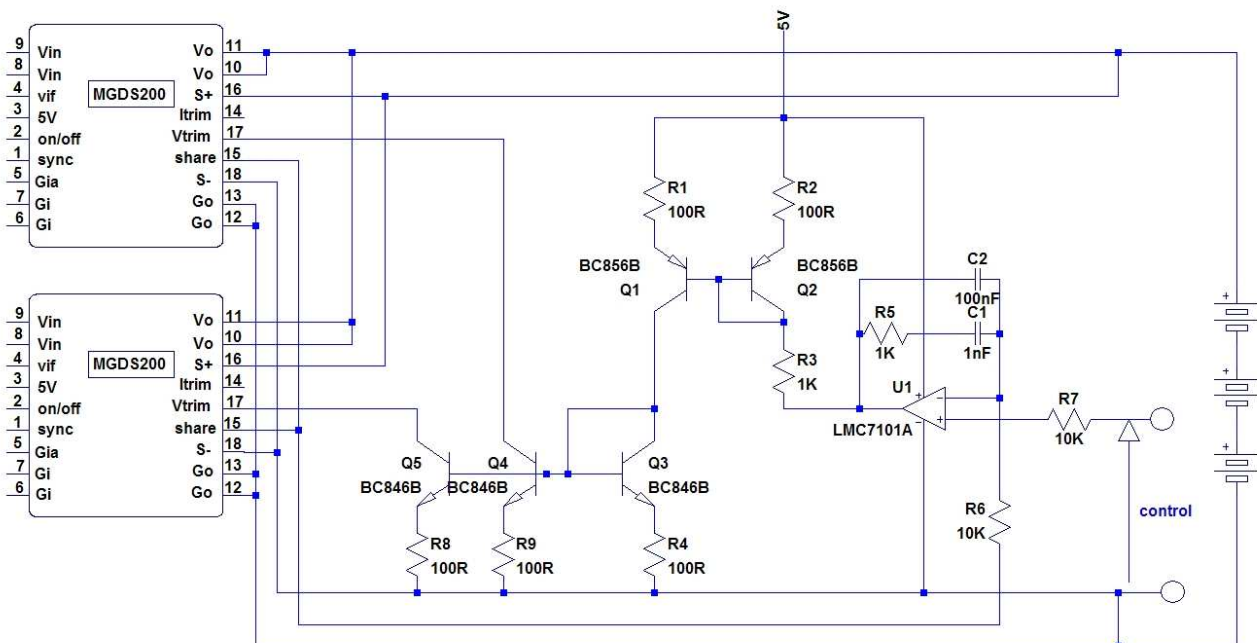

## 3- Advanced Battery Charger

Many new battery technologies require sophisticated charging and monitoring systems to preserve their high performance and to extend their life.

The MGDM-150 and MGDM-200 modules serve as an ideal building block for constructing an advanced battery management system, which typically incorporates a microprocessor-based control circuit that is easily adapted for a variety of battery chemistries and monitoring functions. (See Figure below).

To maintain the optimum charge on the battery, the control circuit independently adjusts the output voltage and charge current in response to conditions during the charge: the battery's voltage, current, temperature and pressure, and other pertinent parameters.

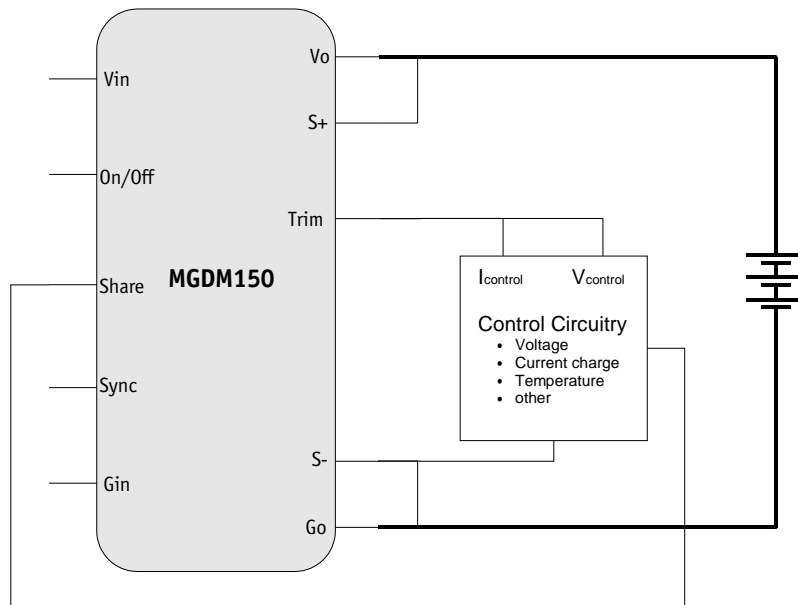



For more detailed specifications and applications information, contact :

**International Headquarters**  
GAIA Converter - France  
ZI de la Morandière  
33185 LE HAILLAN - FRANCE  
Tel. : + (33)-5-57-92-12-80  
Fax : + (33)-5-57-92-12-89

**North American Headquarters**  
GAIA Converter Canada, Inc  
4038 Le Corbusier Blvd  
LAVAL, QUEBEC - CANADA H7L 5R2  
Tel. : (514)-333-3169  
Fax : (514)-333-4519

Represented by :

Information given in this datasheet is believed to be accurate and reliable. However, no responsibility is assumed for the consequence of its use nor for any infringement of patents or other rights of third parties which may result from its use. These products are sold only according to GAIA Converter general conditions of sale, unless otherwise confirmed by writing. Specifications subject to change without notice.