

Modular Power Architecture Up to 300W Power for 24V/28V Avionics/Military Applications

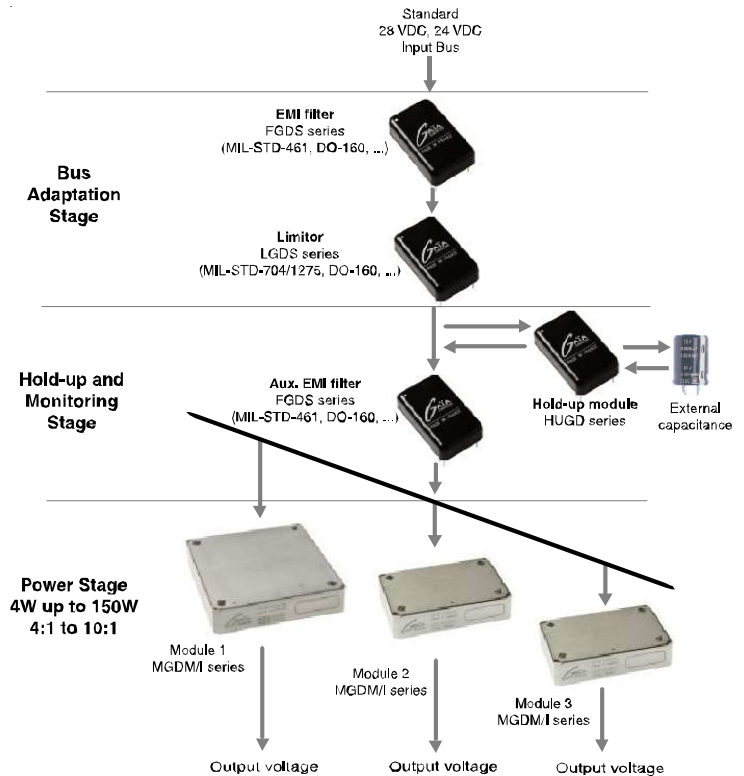

1- General

1-1 Introduction

This application note describes how to use GAIA Converter DC/DC converters and front-end modules to build complete power supply that meets avionic and military standards .

This modular power architecture is dedicated for 24V and 28V bus powered electronics up to 300W power.

1-2 Modular Power Architecture

The use of modular power architecture by using «ready-to-use» building block modules offer to designers many benefits.

Development time is drastically shorter over a traditional custom approach.

The use of standard «mass produced» building block modules is cost-effective over a custom design. It is a versatile and multi-applications oriented, qualification is facilitate by using already qualified building blocks.

1-3 The 24Vdc/28Vdc Input Bus in Avionics/Military Applications

6

The 24Vdc and 28Vdc input busses are one of the most widely used input voltages for medium power in critical systems for :

- airborne applications
- groundborne applications

A lot of constraints are existing around those input busses including transients, spikes, cranking, power transfert, recovery after power fail, electromagnetic interferences,

GAIA Converter has developped a standard easy-to-use and fully qualified modular power architecture to cover all these requirements.

The following sections will underline the different requirements to fulfill in the main area such as :

- Input voltage requirements,
- Electromagnetic interference requirements,
- Output noise requirements,
- Environmental conditions requirements,
- Thermal management.

2- Input Bus Voltage Requirements

2-1 General

Airborne or groundborne electronic systems powered directly from 24Vdc or 28Vdc batteries or generator, shall sustain wide input excursions, including transients, spikes, cranking and shut down.

Those input variations are described in different standards, in which the most frequently used are as follows :

- For Airborne Applications :
 - The US MIL-STD-704 standard : "Aircraft Electric Power Characteristics".
 - The International DO-160 standard : "Environmental Conditions and Test Procedures for Airborne Equipment".
 - The European En 2282 standard : "Characteristics of Aircraft Electrical Supply".
 - The British BSI 3G 100 : "Characteristics of Aircraft Electrical Power Supplies".
 - The Airbus ADB 100 chap. 8 standard : "Equipement Requirements for Suppliers, electric"
- For Groundborne Applications :
 - The US MIL-STD-1275 standard : "Characteristics of 28 VDC Electrical Systems in Military Vehicles".
 - The British DEF STAN 61-5 Part 6 Electrical Power Supply 28 VDC Electrical Systems in Military Vehicles.

2-2 Modes of Operations

The various standards describe different mode of operations :

- Permanent input voltage range in normal, abnormal and emergency conditions,
- Brown-out and transient levels in normal and abnormal conditions,
- Spike levels,
- Start up voltage and cranking levels,
- Shut down (or transparency) levels.

The different permanent input ranges and engine start operation are achieved using GAIA Converter wide input DC/DC modules without any additional devices.

The transients are more aggressive and are achieved by using GAIA Converter limiter modules LGDS series.

The spike protections are achieved using GAIA Converter EMI filter modules : FGDS series

Shut down level is satisfied by an external hold up device (capacitance and/or a GAIA Converter hold up module «HUGD» as exemple). The HUGD module used in conjunction with an external capacitance is a hold-up charger and controller. (see HUGD datasheet for further details).

GAIA Converter proposes typical architecture to cover all these requirements (see figure below).

This architecture includes :

- Front-end modules :
 - EMI filters FGDS series
 - Limiter module LGDS series
 - Hold-Up module HUGD series
- a complete range of DC/DC modules

The front-end modules cover the following operations depending on power bus input status :

Input Bus Status	Active Module	Operations
EMI Filter	FGDS series	EMI filtering and spike supressor
Transients	LGDS series	Transient supressor
Normal	DC/DC	Generation of DC voltages
Hold up	HUGD series	used in conjunction with capacitance to provide energy

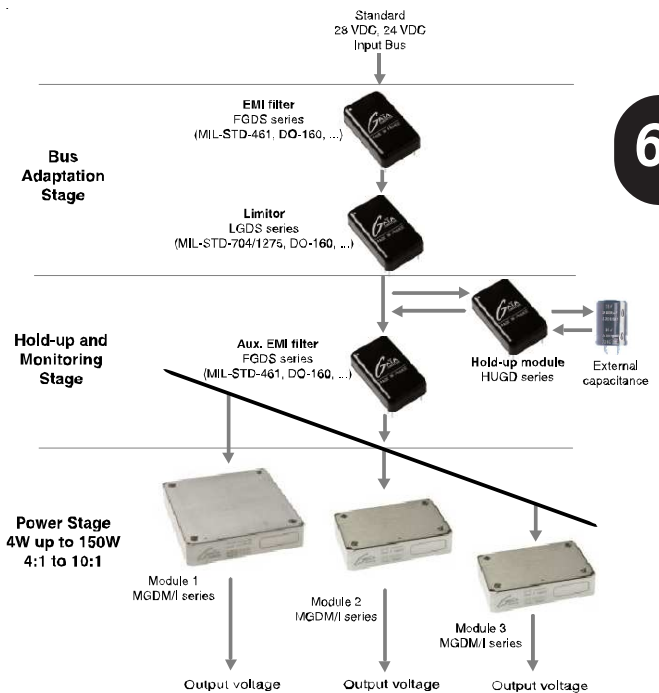

2- Input Bus Voltage Requirements (continued)

The following tables describe for some airborne and groundborne applications the GAIA Converter modular power architecture compliance. Please consult Avionics/Military COTS application note for further details.

2-2 Airborne Applications

International Standards	<----- Steady State ----->			<----- Transient ----->			<- Spike ->	GAIA Converter DC/DC and Front-end Module Compliance
	Normal	Abnormal	Emergency	Low Normal	High Abnormal	Low Abnormal		
	MIL-STD-704A (cat A)	25 - 28,5V	23,5 - 30V	17 - 24V	10V/50ms	80V/50ms		
MIL-STD-704F	22 - 29V	20 - 31,5V	16 - 29V	18V/15ms	50V/50ms	0V/up to 7s	/	GAIA DC/DC range : 16-40V or 16-80V GAIA DC/DC 16-40V with 50V transient or 16-80V HUGD series with capacitor*
DO-160D (cat B) spike cat. A	22 - 30,3V	20,5 - 32,2V	18V	12V/30ms	60V/100ms	0V/up to 7s	+/-600V/10µs	GAIA DC/DC range : 9-36V, 16-40V or 16-80V PGDS series : 10V/15s or GAIA DC/DC range 9-36V PGDS/LGDS series HUGD series with capacitor* FGDS series
DO-160D (cat Z) spike cat. A	22 - 30,3V	20,5 - 32,2V	18V	12V/30ms	80V/100ms	0V/up to 7s	+/-600V/10µs	GAIA DC/DC range : 9-36V, 16-40V or 16-80V PGDS series : 10V/15s or GAIA DC/DC range 9-36V PGDS/LGDS series HUGD series with capacitor* FGDS series
DO-160E (cat Z) spike cat. A	22 - 30,3V	20,5 - 32,2V	18V	12V/30ms	80V/100ms	0V/up to 7s	+/-600V/10µs	GAIA DC/DC range : 9-36V, 16-40V or 16-80V PGDS series : 10V/15s or GAIA DC/DC range 9-36V PGDS/LGDS series HUGD series with capacitor* FGDS series
AIR2021E	24 - 29V	20,5 - 32,2V	17V	12V/30ms	60V/50ms	0V/up to 5s	+/-600V/10µs	GAIA DC/DC range : 9-36V, 16-40V or 16-80V PGDS series : 10V/15s or GAIA DC/DC range 9-36V PGDS/LGDS series HUGD series with capacitor* FGDS series

Note * : the duration of low abnormal condition 0V has to be specified by the user, the maximum duration will be limited according to the power needed and the HUGD maximum capacitance, refer to HUGD datasheet.

2-2 Groundborne Applications

International Standards	Steady State	Start Engine	Cranking	<----- Surge ----->		Spike	GAIA Converter DC/DC and Front-end Module Compliance
				Low	High		
MIL-STD-1275C/D (generator + battery)	25 - 30V	6V/1s	16V/30s	20V/500ms	40V/50ms	+/-40V/1ms/15mJ +/-250V/70µs/15mJ	GAIA DC/DC range : 9-45V or 9-36V with 40V/100ms PGDS series : 6V/1s FGDS series
MIL-STD-1275C/D (battery only)	20 - 27V	6V/1s	16V/30s	/	/	+/-40V/1ms/15mJ +/-250V/70µs/15mJ	GAIA DC/DC range : 9-45V or 9-36V with 40V/100ms PGDS series : 6V/1s FGDS series
MIL-STD-1275C/D (generator only)	23 - 33V	/	/	15V	100V/50ms	+/-100V/1ms/15mJ +/-250V/50µs/15mJ	GAIA DC/DC range : 9-45V or 9-36V PGDS/LGDS series FGDS series
DEF STAN 61-5 issue 5 (generator + battery)	25 - 30V	6V/1s	>15V	20V/500ms	40V/50ms	+130V/-100V/<10µs +90V/-60V/10µs +70V/-40V/5ms	GAIA DC/DC range : 9-45V or 9-36V with 40V/100ms PGDS series : 6V/1s FGDS series PGDS/LGDS series
DEF STAN 61-5 issue 5 (battery only)	22 - 27V	1V/1s	>10V	/	/	+130V/-100V/<10µs +90V/-60V/10µs +70V/-40V/5ms	GAIA DC/DC range : 9-45V or 9-36V with 40V/100ms External capacitance FGDS series FGDS series PGDS/LGDS series
DEF STAN 61-5 issue 5 (generator only)	15 - 40V	/	/	15V/500ms	80V/80ms	+280V/-220V/<10µs +130V/-70V/10µs +110V/-50V/5ms	GAIA DC/DC range : 9-45V or 9-36V PGDS/LGDS series FGDS series FGDS series PGDS/LGDS series

2- Input Bus Voltage Requirements (continued)

2-4 Input Bus Shut-Down Requirements

When input bus voltage shut-down the use of a storage energy device is necessary.

There are 2 ways to comply :

- the use of a stand-alone bulk capacitor
- the use of GAIA Converter HUGD module together with a capacitor.

Both solutions are described thereafter.

10-1-1 Capacitor Stand-Alone Solution

To maintain operation during power drop-out, the traditional approach is to use a bulk capacitor connected at the input of the converters to power them when power drops-out. This capacitor depends on the system specifications, the load, the efficiency of the DC/DC converter and the hold-up time requirement. The value of the capacitance is determined by the following formula :

$$C1 = \frac{2 \times P \times Dt}{h \times (V1^2 - V2^2)}$$

where :

- C : is the required capacitor (in farads)
- P : is the power at the load (output of converter)
- h : is the efficiency of the converter at rated load
- Dt : is the required hold up time (in seconds)
- V1 : is the initial charged capacitor voltage (in volts)
- V2 : is the low line voltage of DC/DC converter

For a typical 100ms hold-up time requirement with 200W output power, and a GAIA Converter module with a minimum permanent input voltage at 9V with 80% efficiency connected on a MIL-STD-704 28V bus that can range down to 22V, the resulting capacitor is a large $(2 \times 200 \times 0,1) / (0,8 \times (28^2 - 9^2)) = 72\ 150\ \mu\text{F}$ capacitance so a 82 000 $\mu\text{F}/40\text{V}$ bulk capacitor or even larger if we consider the initial voltage as the minimum permanent input bus voltage (i.e 22V).

Using stand alone capacitor conduct to face 2 main issues:

- 1) Voltage before interruption (V1) follows the input bus minimum steady state, reducing by the way the stored energy when bus is at its low value. In some case the Hold-up is not possible because $V1 < V2$.
- 2) Needed hold up capacitor value are so large than inrush current at 1st step of charging need to be limited by external circuitry.

10-1-2 Capacitor with Hold Up Module Solution

To reduce drastically the size of this capacitor, GAIA Converter proposes the HUGD-300 hold-up module that will charge the capacitor at a higher voltage (typically from 31V to 80VDC).

Moreover this module also allows to select the minimum threshold voltage at which the capacitance will power the converters. In this case the amount of capacitance needed for a given hold up time is determined by the following formula :

$$C2 = \frac{2 \times P \times (Dt + 0.01)}{h \times (Vcset^2 - V2^2)}$$

where :

- C : is the required capacitor (in farads)
- P : is the power to the load (output of converter) (in watts)
- h : is the efficiency of the converter at rated load
- Dt : is the required hold up time (in seconds)
- Vcset : is the capacitor charge voltage set from HUGD-300
- V2 : is the low line voltage of DC/DC converter (in volts).

For a typical 100ms hold-up time requirement with 200W output power, and a GAIA Converter module with a minimum permanent input voltage at 9V with 80% efficiency connected on a MIL-STD-704 28V bus, using the HUGD-300 set for a capacitor charge voltage of 60VDC will reduce the capacitance value down to $(2 \times 200 \times 0,11) / (0,8 \times (60^2 - 9^2)) = 12\ 500\ \mu\text{F}$ so a typical 16.000 $\mu\text{F}/80\text{V}$ bulk capacitor.

The HUGD-300 takes the advantage of boosting hold-up capacitor voltage to enlarges the V1-V2 voltage difference whatever the input bus voltage before hold-up is.

The gain is not proportional to V2 but to $V2^2$ so stored energy is growing according to a quadratic curve. In addition the HUGD-300 manages the inrush current without necessity of external circuitry.

3- Electromagnetic Interference Compatibility Requirement

Airborne or groundborne electronic systems shall also sustain severe level of electromagnetic interference requirements.

Those interference levels are defined in different standards whereas the most popular are :

- The US MIL-STD-461C standard : “Electromagnetic Interference Characteristics, Requirements for Equipment”.
- The US MIL-STD-461D/E/F standards : «Requirements for the control of electromagnetic Interference Emissions and Susceptibility».

- The DO-160C/D/E/F/G standard : “Environmental Conditions and Test Procedures for Airborne Equipment”.

The requirements are divided into :

- Conducted emission (CE),
- Conducted susceptibility (CS),
- Radiated emission (RE),
- Radiated susceptibility (RS).

The following tables resume GAIA Converter products compliance with the requirements

Specifications	MIL-STD-461C	MIL-STD-461D/E/F	DO-160C/D/E/F/G	GAIA Converter Module Compliance
Conducted emission (CE) :				
Low frequency	CE 01	CE 101	Section 21	module compliant stand alone (see product datasheet)
High frequency	CE 03	CE 102	Section 21	module compliant with additional filter
Conducted susceptibility (CS) :				
Low frequency	CS 01	CS 101	Section 20	module compliant with additional filter
High frequency	CS 02	CS 114	Section 20	module compliant with additional filter
Radiated emission (RE) :				
Magnetic field	RE 01	RE 101	Section 21	module compliant stand alone (see product datasheet)
Electrical field	RE 02	RE 102	Section 21	module compliant stand alone (see product datasheet)
Radiated susceptibility (RS) :				
Magnetic field	RS 01	RS 101	Section 20	module compliant stand alone (see product datasheet)
Electrical field	RS 03	RS 103	Section 20	module compliant stand alone (see product datasheet)

3-1 Compliance with DO-160C/D/E/F/G and MIL-STD-461C/D/E/F Standards

To meet the international DO-160C/D/E/F/G and US military standards MIL-STD-461C, MIL-STD-461D/E/F requirements and in particular CE03 and CE102 requirements, Gaïa Converter can propose ready-to-use EMI filter module : FGDS series.

For better EMI performance and stability purpose, GAIA Converter recommends to use a R*C* cell together with 4 decoupling capacitors Cc (10nF typical) connected between input and case and output and case of the DC/DC converter.

Typical value of capacitor C* is 10µF, typical value of resistor R* being the equivalent serial resistor ESR of C*.

Please consult EMI filter FGDS-10A-50V or FGDS-20A-50V datasheet for further details.

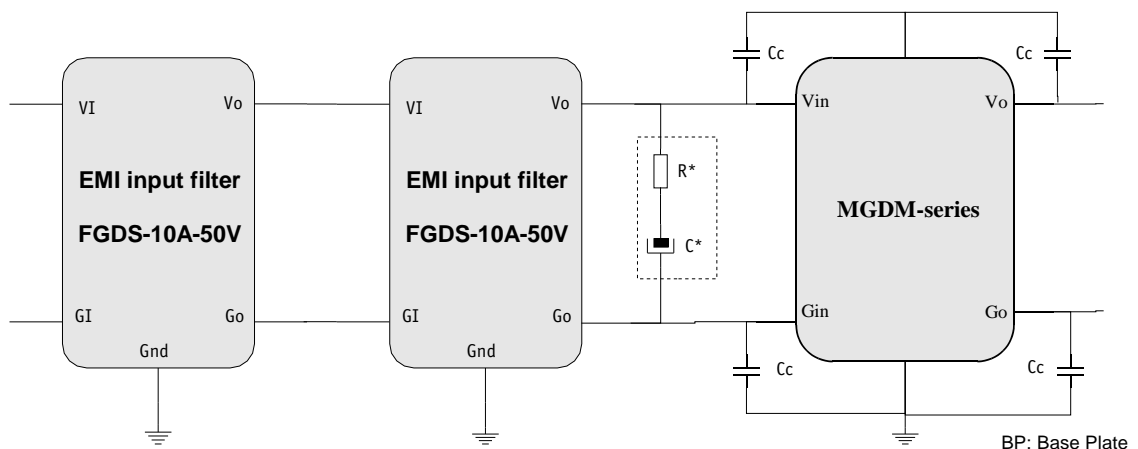

4- Typical Architecture Schematics with Multiple Modules

Typical architecture up to 300W power can be designed in 2 ways :

- design with 2 separate EMI cells
- design with 2 neighbour EMI cells

Both architectures integrates re-inforced front spike suppressor TVS for lightning protection if necessary.

Both architecture integrates 2 EMI filter modules FGDS series (see FGDS-10A-50V or FGDS-20A-50V datasheet for further details) together with individual DC/DC converter decoupling capacitor (see in individual DC/DC converter datasheet).

The separate EMI cell architecture integrates a schematics with N channel power MOSFET connected to LGDS-300 for reverse polarity protection (see LGDS-300 datasheet for further details).

GAIA Converter recommends also to place a 220µF/50V capacitor for stability purpose.

For the neighbour EMI cell architecture, GAIA Converter recommends for better EMI performance to use a R*C* cell (see FGDS-20A-50V datasheet for further details) typically a 100µF/100V the R* value being the capacitor ESR value

Typical Architecture Schematics with separate EMI cells

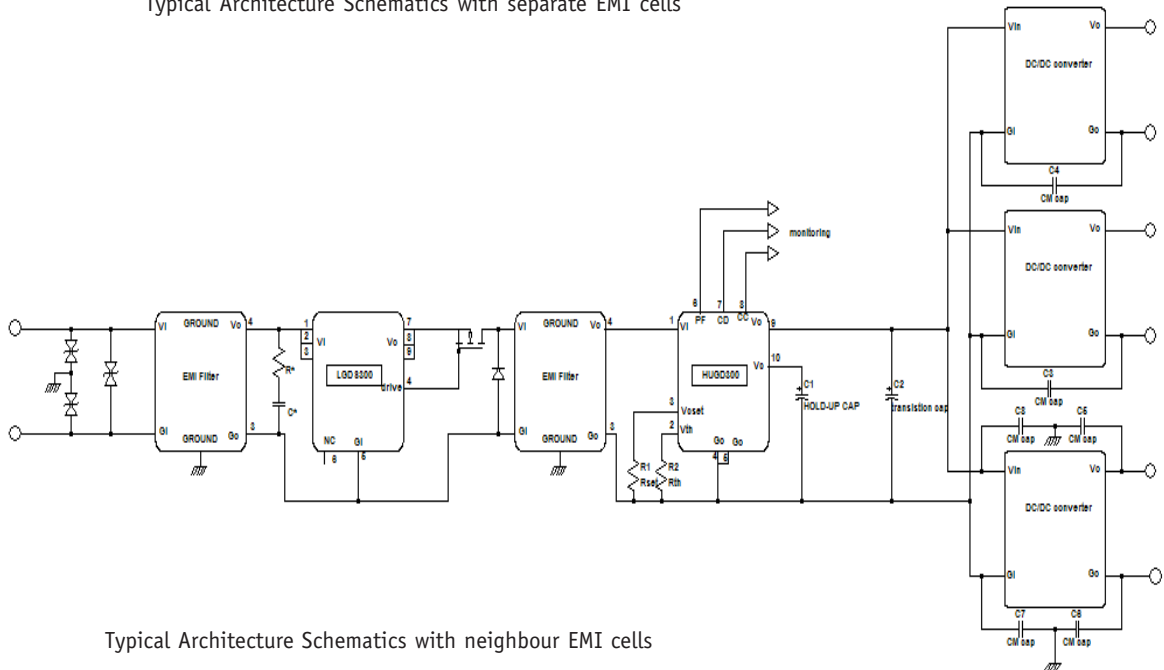

Typical Architecture Schematics with neighbour EMI cells

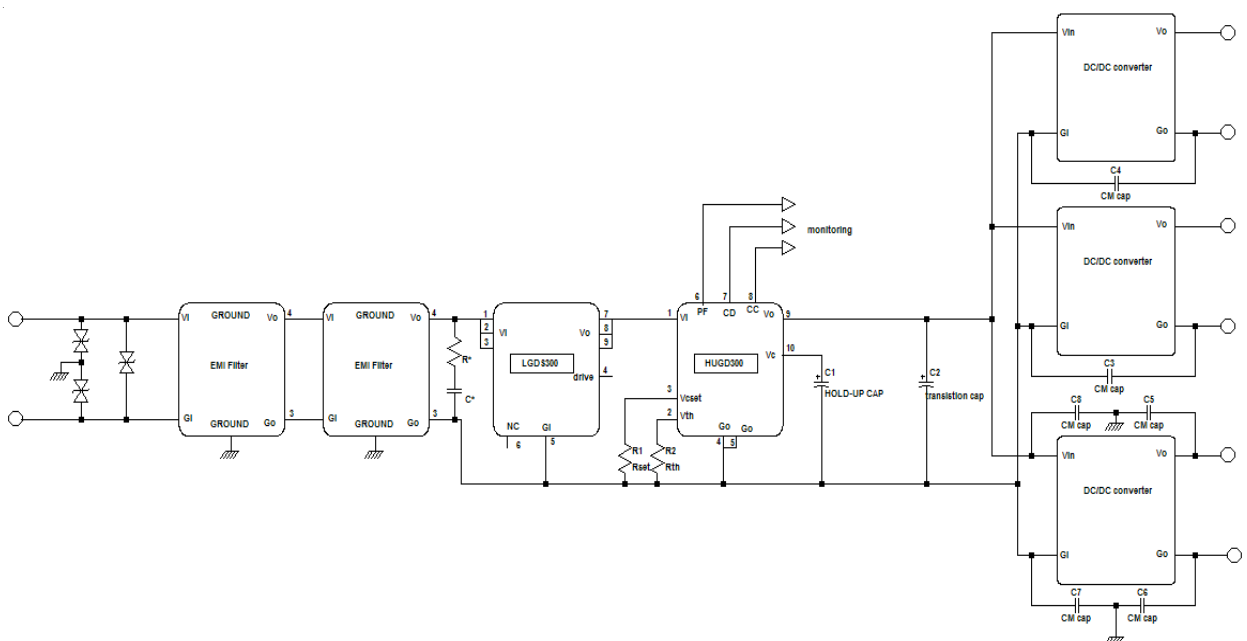

4- Lay-out Recommendation

Good printed circuit board layout design is essential to achieve proper EMI performance. The two key areas to consider while laying-out a board are :

- Component and trace routing,
- Grounding design.

4-1 Component and trace routing design

The first step while placing the parts is to determine the power flow through the board.

- The optimum design, is from one side of the board to the other, avoiding cross-overs.
- Another possibility is a design where both power input and power output buses are on the same edge of the board (see figure herunder). In such a case, keep as much distance as possible between input and output buses.

The second step is to place the EMI filter as close as possible from the input connector and create a "clean area" including EMI filter and input bus protection.

The third step is to lay-out the power stage "noisy area". If multiple modules are used, it is recommended to leave at least 0.5 inch between each module to avoid radiation from power stage of one module to perturb control stage of the nearby modules and cause cross-talk or jitter.

It is recommended to place 10nF common mode capacitors between each Vi, Gi, Vo and Go pins and mounting holes with connection to chassis ground for decoupling. These capacitors should be connected as closed as possible from pins While routing, do not mix or overlap filtered power traces (e.g. filter's input bus) with unfiltered and noisy power traces (e.g. filter's output bus) as this would dramatically degrade the filter performance. Keep filtered power traces clearly separated and away from unfiltered power traces, for example each on one side of the filter. Also, keep sensitive low level signal traces away from the power bus.

4-2 Grounding design

Gaia Converter recommends to use multilayer boards with 3 main grounding areas : chassis ground, Gin ground and Gout ground. Keep the necessary distance for voltage insulation between the different ground areas and vias or through hole pins. Preferably, the grounding areas are plane areas better than grid areas.

The chassis ground plane has to stay in open loop.

The Gin ground plane could be routed in an internal layer to be as homogeneous as possible to provide both a low impedance path and to act as a heatsink for thermal management, preferably on the layer closest to heat generating sources.

This plane should be spread all over the board except under filtered (clean area) and sensitive low level areas. It's design should be such that it doesn't create any ground loop. As a consequence, it should also not run under the filtered input bus.

The Gout ground plane could be routed in an internal layer with all output pin connections.

The «case» pin of the modules (if available) can be connected to the chassis ground plane to achieve a 6 sides shield.

Figure herunder depicts a typical lay-out design.

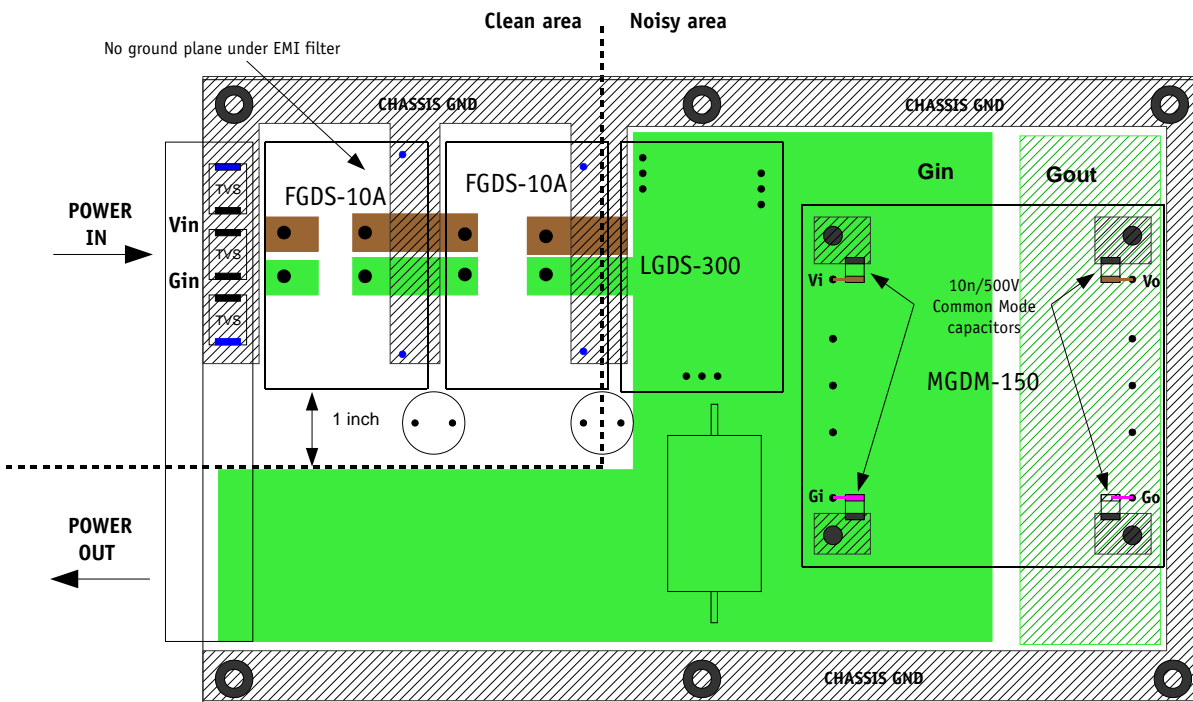

5- Compliance with Environmental Condition Requirements

Avionics and military electronic systems shall sustain a high level of environmental conditions depending on their use/location.

The levels are defined in different standards, among which the most frequently used are :

- The RTCA/DO-160C standard : "Environmental Conditions and test Procedures for Airborne Equipment".
- The US MIL-STD-810 standard : "Environmental Test Method".
- The US MIL-STD-202 standard : "Environmental Test Method".

- The US MIL-STD-883 standard : "Screening Procedures".
- The French GAM-EG 13B standard : "Essais de comptabilité à l'environnement climatique, mécanique"
- The UK BS3G100 standard : "Environmental Conditions Test Method".

To verify the suitability of GAIA Converter modules, a complete qualification test program has been undertaken by an independent laboratory part of the French Defense Agency CELAR which includes :

Tests	Standards	GAIA Converter DC/DC module qualification
Life at high temperature	per MIL-STD-202G Method 108A	Operation : 1.000 hrs @ +105°C case Storage : 1.000 hrs @ +125°C ambient
Low temperature	per MIL-STD-810E/G Method 502.3/502.5	Storage : 1.000 hrs @ -55°C ambient
Temperature cycling	per MIL-STD-202A Method 102A	Number of cycles : 200 Temperature change : -40°C / +85°C Transfert time : 40 min. Steady state time : 20 min
Temperature shock	per MIL-STD-202G Method 107G	Number of shocks : 50 Temperature change : -55°C / +105°C Transfert time : < 10 sec Steady state time : 30 min
Low Pressure (Altitude)	per MIL-STD-810E/G Method 500.3/500.5	40.000ft, unit functioning 1.000ft/min to 70.000ft,unit functioning
Humidity (Cyclic)	per MIL-STD-810E/G Method 507.3/507.5	Damp heat : 60% to 88% relative humidity Cycle I : (31°C to 41°C) : 240Hrs
Humidity (Steady state)	per MIL-STD-202G Method 103B	Damp heat : 93% relative humidity Temperature : 40°C Duration : 56 days
Salt spray	per MIL-STD-810E/G Method 509.3/509.5	Temperature : 35°C Duration : 48 hrs
Vibration Frequency range Acceleration	per MIL-STD-810D/G Method 514.3/514.6	10 cycles in each axis frequency : 10 to 60Hz/60 to 2 KHz acceleration : 0.7mm/10g
Shock (Half sinus) Peak acceleration Duration	per MIL-STD-810D/G Method 516.3/516/6	3 shocks in each axis Peak acceleration : 100g duration : 6ms
Bumps	per MIL-STD-810D/G Method 516.3/516.6	2000 bumps in each direction duration : 6ms peak acceleration : 40g

6- Thermal Management

GAIA Converter modules are given for a maximum case or baseplate temperature of 105°C. This temperature corresponds to an internal component temperature far below (design derating) their maximum junction temperature.

Usually for designer, environment is explained with ambient temperature. To rapidly check if this ambient condition is compliant with the maximum case temperature, the first step is to find the power dissipated in the converter, this value is calculated as follow :

$$P_{\text{dissipation}} = P_{\text{out}} / \text{efficiency} - P_{\text{out}}$$

(Efficiency is given for each module in the technical datasheet)

GAIA Converter provides for each Hi-Rel converter the thermal resistance Rth case ambient by watt dissipated so the maximum ambient temperature is given with the formula :

$$T_{\text{ambient}} = 105^{\circ}\text{C} - P_{\text{diss}} * R_{\text{th}}$$

Where Tambient is given in °C

If calculated ambient temperature is not compliant with the requirement an additional thermal path should be found to lower the thermal resistance with :

- Heat sink
- Forced air cooling
- Larger area of circuit board metallization.

A method of removing heat recommended by GAIA Converter is conductive heat sink through direct contact with the module case. Complete thermal details are given in Thermal application note

An example is given in the following application where heat sink is provided by the top case in conductive metal.

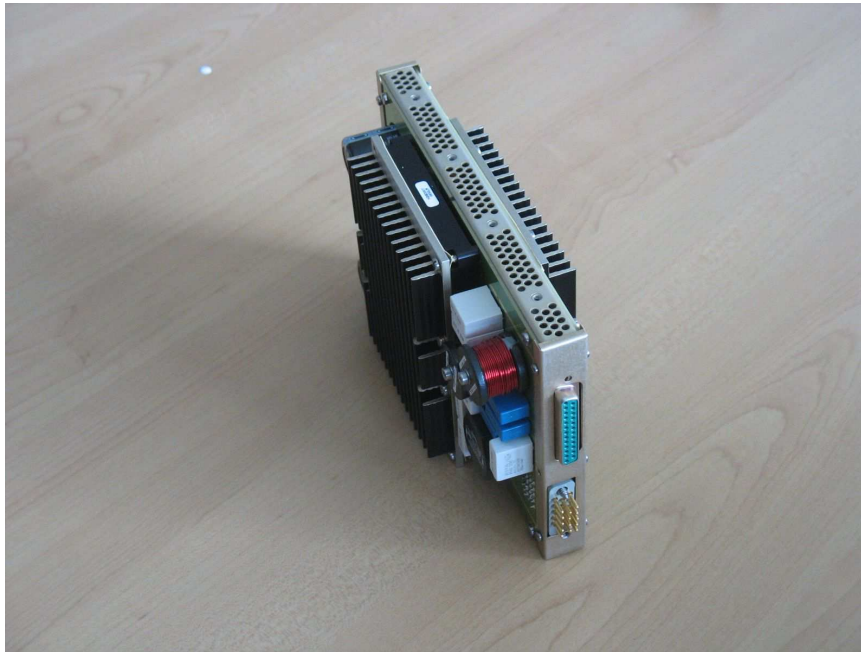



For more detailed specifications and applications information, contact :

International Headquarters

GAIA Converter - France
ZI de la Morandière
33185 LE HAILLAN - FRANCE
Tel. : + (33)-5-57-92-12-80
Fax : + (33)-5-57-92-12-89

North American Headquarters

GAIA Converter Canada, Inc
4038 Le Corbusier Blvd
LAVAL, QUEBEC - CANADA H7L 5R2
Tel. : (514)-333-3169
Fax : (514)-333-4519

Represented by :