



Industrial DC/DC CONVERTER MGDI-25 Standard Input : 25W POWER

Industrial Grade ■

**2:1 Standard Input
Single Output
Metallic case - 1.500 VDC Isolation**



- Wide input range
- Nominal power up to 25/30 W
- Wide temperature range : -40°C/+ 95°C case
- High efficiency (up to 89%)
- Soft start
- Galvanic isolation 1.500 VDC according to EN 60950
- Integrated LC EMI filter
- Permanent short circuit protection
- No optocoupler for high reliability
- RoHS process

1-General

The MGDI-25 series is a complete line of DC/DC power modules designed for use in distributed power architecture and are particularly suitable for mobile or ground fixed applications in transportation, industrial and telecommunication areas. These modules use a high frequency fixed switching technic at 250KHz providing excellent reliability, low noise characteristics and high power density. Standard models are available with wide input voltage range of 45-100 volts. The series include single output voltage choices of 5, 12, 15, 24 volts.

No external heatsink is required for the MGDI-25 series to supply 25W to 30W output power over the full temperature range.

The MGDI-25 series is designed in conformity with safety standards EN60950 and UL1950.

All the modules are designed with LC network filters to minimize reflected input current ripple and output voltage ripple according to EN55022 and FCC Part 15J standard.

The modules include a soft-start, a permanent short circuit protection and an output overvoltage protection to ensure efficient module protections. The soft-start allows current limitation and eliminates inrush current during start-up. The short circuit protection completely protects the modules against short-circuits of any duration by a shut-down and restores to normal when the overload is removed.

The design has been carried out with surface mount components and is manufactured in a fully automated process to guarantee high quality. Each module is tested with a GAIA Converter automated test equipment.

5

2-Product Selection

Single output model : MGDSI - 25 - -

Input Voltage Range
Permanent
K : 45-100 VDC

Output
C : 5 VDC
E : 12 VDC
F : 15 VDC
I : 24 VDC

2- Product Selection (continued)

Input range	Output	Current	Reference	Options
45-100 VDC	5 VDC	5 A	MGDSI-25-K-C	/
45-100 VDC	12 VDC	2,5 A	MGDSI-25-K-E	/
45-100 VDC	15 VDC	2 A	MGDSI-25-K-F	/
45-100 VDC	24 VDC	1,25 A	MGDSI-25-K-I	/

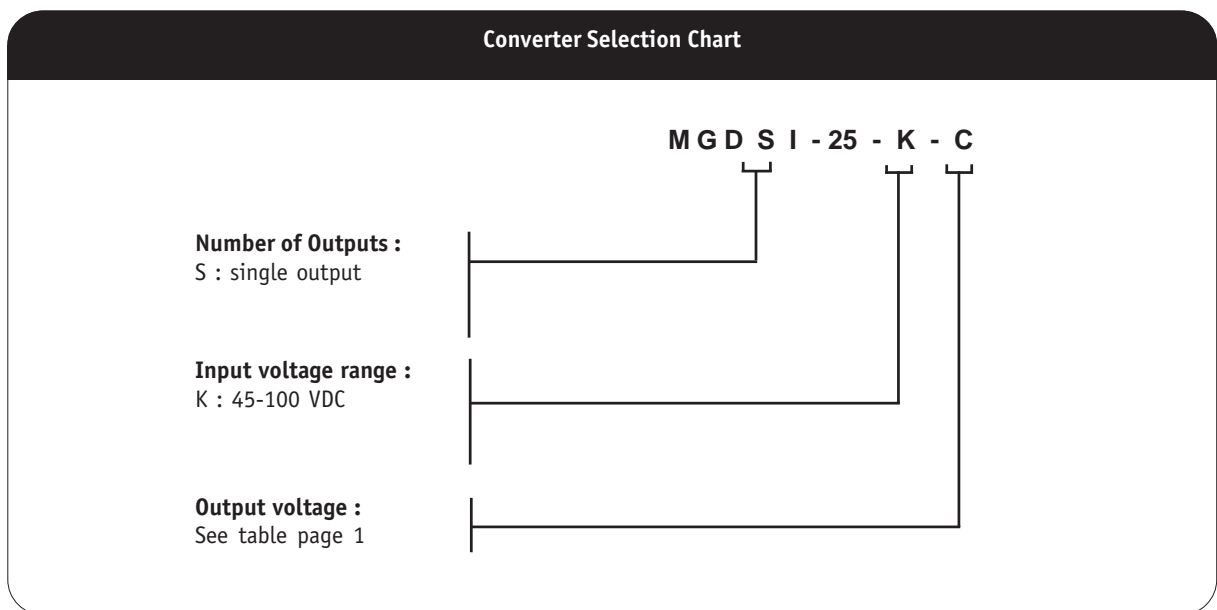

3- Electrical Specifications

Data are valid at +25°C, unless otherwise specified.

Parameter	Conditions	Limit or typical	Units	Single Output MGDSI-25- K
Input				
Nominal input voltage	Full temperature range	Nominal	VDC	72
Permanent input voltage range (Ui)	Full temperature range	Min. - Max.	VDC	45-100
Start up time	Ui nominal Nominal output Full load : resistive	Maximum	ms	20
Reflected ripple current	Ui nominal, full load at switching freq. BW = 20MHz	Typical	mApp	300
Input current in short circuit mode (Average)	Ui nominal Short-circuit	Typical	mA	40
No load input current	Ui nominal No load	Maximum	mA	60
Output				
Output voltage	Full temperature range Ui min. to max. 75% load	Nominal	VDC	5
		Nominal	VDC	12
		Nominal	VDC	15
		Nominal	VDC	24
Set Point accuracy	Ambient temperature : +25°C Ui nominal, 75% load	Maximum	%	+/- 2
Output power	Full temperature range Ui min. to max.	Maximum	W	20/30
Output current	Full temperature range Ui min. to max.	Maximum	A	5
5V output		Maximum	A	2,5
12V output		Maximum	A	2
15V output		Maximum	A	1,25
24V output				
Ripple output voltage *	Ui nominal Full load BW = 20MHz	Maximum	mVpp	50
5V output		Maximum	mVpp	100
12V output		Maximum	mVpp	150
15V and 24V output				
Line regulation	Ui min. to max. Full load	Typical	%	+/- 1
Load regulation **	Ui nominal 25% to full load	Typical	%	+/- 2,5
Efficiency	Ui nominal Full load	Typical	%	86
5V output		Typical	%	88
12V and 15V output		Typical	%	89
24V output				
Maximum admissible Capacitive load	Ui nominal Full load Per output	Maximum	µF	1.000

Note *: The ripple output voltage is the periodic AC component imposed on the output voltage, an aperiodic and random component (noise) has also to be considered. This noise can be reduced by adding an external capacitor (typically 10nF/rated voltage depending on isolation requirement) connected between the pin Gin and the pin Gout of the converter. This capacitor should be layed-out as close as possible from the converter.

Note **: For load regulation characteristics from 0% to full load, please contact factory.

4- Switching Frequency

Parameter	Conditions	Limit or typical	Specifications
Switching frequency	Full temperature range Ui min. to max. No load to full load	Nominal, fixed	250 KHz

5- Isolation

Parameter	Conditions	Limit or typical	Specifications
Electric strength test voltage (basic version)	Input to output	Minimum	1.500 VDC / 1 min
Electric strength test voltage between outputs (for dual and triple outputs)	Output to output	Minimum	No isolation
Isolation resistance	500 VDC	Minimum	100 MOhm

6- Protection Functions

Characteristics	Protection Device	Recovery	Limit or typical	Specifications
Output short circuit protection (SCP)	Hiccup circuitry with auto-recovery	Automatic recovery	Permanent	See section 10
Output overvoltage protection (OVP)	Zener clamp	/	Maximum Maximum Maximum Maximum	For 3.3v : 4.6v For 5v : 6v For 12v : 14v For 15v : 17v

7- Reliability Data

Characteristics	Conditions	Temperature	Specifications
Mean Time Between Failure (MTBF) According to MIL-HDBK-217F	Ground fixed (Gf)	Case at 40°C Case at 70°C	925.000 Hrs 350.000 Hrs
	Ground mobile (Gm)	Case at 40°C Case at 70°C	445.000 Hrs 148.000 Hrs
Mean Time Between Failure (MTBF) According to IEC-62380-TR	Telecom switchers	/	Consult factory

8- Thermal Characteristics

Characteristics	Conditions	Limit or typical	Performances
Operating ambient temperature range at full load	Ambient temperature *	Minimum Maximum	- 40°C + 71°C
Operating case temperature range at full load	Case temperature	Minimum Maximum	- 40°C +95°C
Storage temperature range	Non functioning	Minimum Maximum	- 40°C + 105°C
Thermal resistance	Rth case to ambient in free air natural convection	Typical	7°C /W

Note *: The upper temperature range depends on configuration, the user must assure a max. case temperature of + 95°C.

The MGDI-25 series operating **case** temperature at full load must not exceed 95°C. The maximum **ambient** temperature admissible for the DC/DC converter corresponding to the maximum operating case temperature of 95°C depends on the ambient airflow, the mounting/orientation, the cooling features and the power dissipated.

To calculate a maximum admissible ambient temperature the following method can be used. Knowing the maximum case temperature Tcase = 95°C of the module, the power used Pout and the efficiency η :

- determine the power dissipated by the module P_{diss} that should be evacuated :

$$P_{diss} = P_{out}(1/\eta - 1)$$

- determine the maximum ambient temperature :

$$T_a = 95^\circ\text{C} - R_{th} \times P_{diss}$$

where **Rth** is the thermal resistance from the case to ambient.

The previous thermal calculation shows two areas of operation :

- a normal operation area in a free natural ambient convection (grey area in this following graph),
- an area with cooling features (air flow or heatsink) ensuring a maximum case temperature below the maximum operating case temperature of 95°C at full load (white area in the following graph).

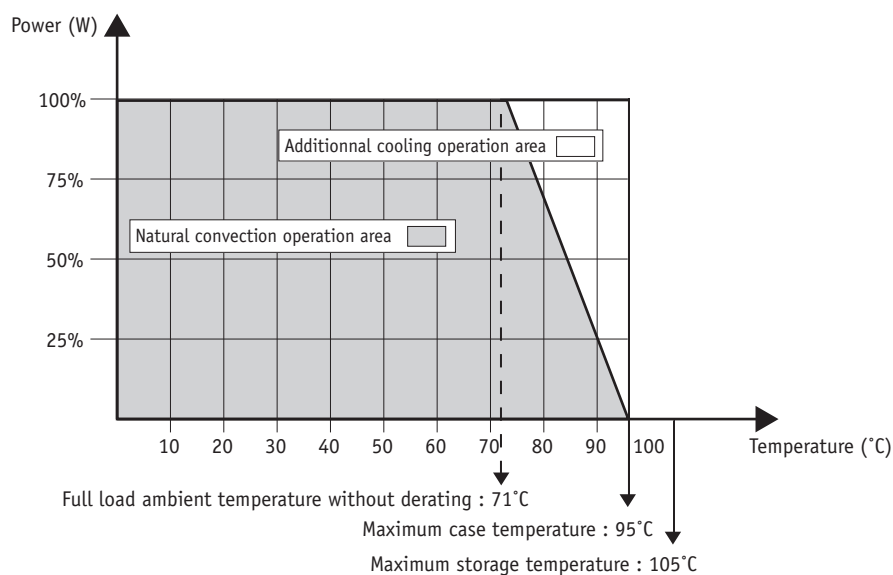

9- Environmental Qualifications

The modules have been subjected to the following environmental qualifications.

Characteristics	Conditions	Severity	Test procedure
Climatic Qualifications			
Life at high temperature	Duration Temperature Status of unit	1.000 Hrs 95°C case unit operating	IEC 68-2-2
Humidity steady	Damp heat Temperature Duration Status of unit	93 % relative humidity 40°C 56 days unit not operating	IEC 68-2-3 Test Ca
Temperature cycling	Number of cycles Temperature change Transfert time Steady state time Status of unit	200 -40°C / +71°C 40 min. 20 min. unit not operating	IEC 68-2-14 Test N
Temperature shock	Number of shocks Temperature change Transfert time Steady state time Status of unit	50 -40°C / +105°C 10 sec. 20 min. unit not operating	IEC 68-2-14 Test Na
Mechanical Qualifications			
Vibration (Sinusoidal)	Number of cycles Frequency : amplitude Frequency : acceleration Amplitude /acceleration Duration Status of unit	10 cycles in each axis 10 to 60 Hz / 0.7 mm 60 to 2000 Hz / 10 g 0.7 mm/10 g 2h 30 min. per axis unit not operating	IEC 68-2-6 Test Fc
Shock (Half sinus)	Number of shocks Peak acceleration Duration Shock form Status of unit	3 shocks in each axis 100 g 6 ms 1/2 sinusoidal unit not operating	IEC 68-2-27 Test Ea
Bump (Half sinus)	Number of bumps Peak acceleration Duration Status of unit	2000 bumps in each axis 25 g 6 ms unit not operating	IEC 68-2-29 Test Eb
Electrical Immunity Qualifications			
Electrical discharge susceptibility	Number of discharges Air discharge level Contact discharge level Air discharge level Contact discharge level	10 positive & 10 negative discharges 4 kV : sanction A 2 Kk : sanction A 8 Kk : sanction B 4 kV : sanction B	EN55082-2 with : EN61000-4-2 IEC 801-2
Electrical field susceptibility	Antenna position Electromagnetic field Wave form signal Frequency range	at 1 m 10 V/m AM 80%, 1 kHz 26 MHz to 1 GHz	EN55082-2 with : EN61000-4-3 IEC801-3
Electrical fast transient susceptibility	Burst form Wave form signal Impedance Level 1 Level 3	5/50 ns 5 kHz with 15 ms burst duration period 300 ms 50 Ohm 0,5 kV : sanction A 2 kV : sanction B	EN55082-2 with : EN61000-4-4 IEC801-4

10- Description of Protections

10-1 Output Short Circuit Protection (SCP)

The short circuit protection device protects the module against short circuit of any duration and restores the module to normal operation when the short circuit is removed. It operates in «hiccup» mode by testing periodically if an overload is applied (typically every 1s recovery time). The overload detection threshold is typically 200% of maximum current with a detection time lower than 5ms.

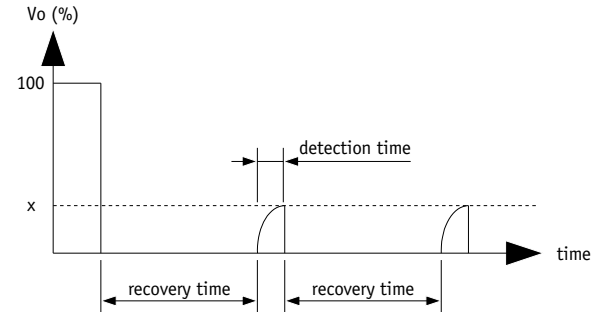

10-2 Output Overvoltage Protection (OVP)

The output overvoltage protection device protects external components against high voltage or possible overvoltages which can be supplied by the module (i.e in case of internal failure). It consists of a zener diode clamping the output voltage; under worst case conditions this zener diode will short-circuit.

The output voltage protection is not designed to withstand externally applied output overvoltages to protect the module itself.

11- Application Notes

11-1 Connection of Outputs in Series

Any of the bi output converters can be configured to produce an output of 10V (+/-5 output models), 24V (+/-12V output models), or 30V (+/-15V output models) by connecting the load across the output (+) and the output (-) with either output grounded, and leaving the common pin floating.

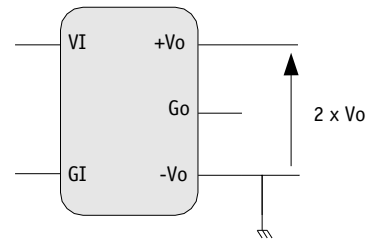

11-2 Connection of Modules in Series

The output of single output units can be connected in series without any precautions to provide higher output voltage level.

Nevertheless, GAIA Converter recommends to protect each individual output by a low power shottky diode rated with the maximum current of the converter to avoid reverse polarity at any output.

Reverse polarity may occur at start up if the output voltages do not rise at the same time.

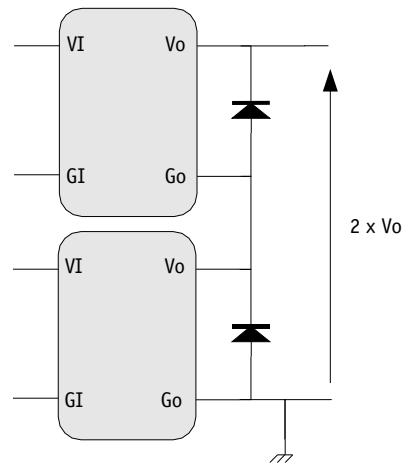

11-3 Connection of Modules in Parallel

Several converters with equal output voltage can be connected in parallel to increase power. Nevertheless some cares have to be taken in particular as the output voltage of each converter is slightly different, when paralleling, the converter with the highest output voltage will source the most current.

However the GAIA Converter modules are designed with a "soft" output voltage versus current characteristic. This causes the output voltage of each converter to automatically adjust downward as its current increases so each converter very approximately shares the total output current. It is important that each converter has approximately the same impedance between their output and the common load.

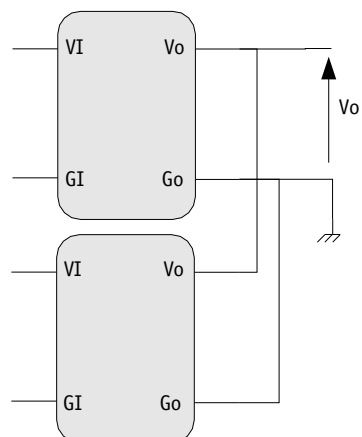

12- Dimensions

Dimensions are given in mm (inches). Tolerance : +/- 0,2 mm (+/- 0.01 ") unless otherwise indicated.
Weight : 80 grams (2.8 Ozs) max.

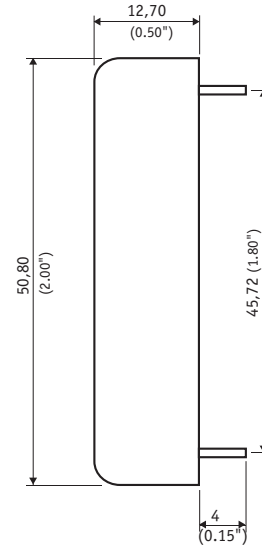
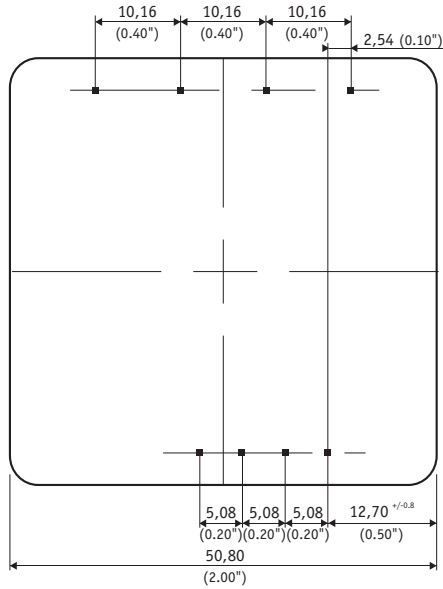

Pin dimensions : \square 0,91 mm (0.036 ")

13- Materials

Case : Metallic black painted coating.

Pins : Plated with pure matte tin over nickel underplate.

14- Product Marking

Upper face : Company logo, location of manufacturing.

Side face : Module reference, option, date code : year and week of manufacturing.

15- Connections

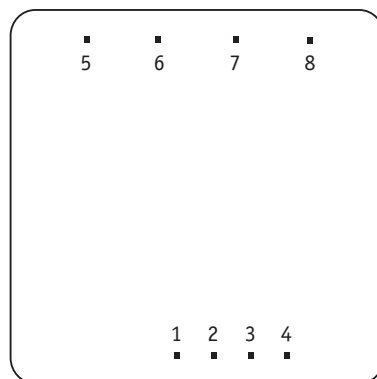

Bottom view

Pin	Single
1	+ Input (Vi)
2	- Input (Gi)
3	Case
4	Do not connect
5	Do not connect
6	Output (Vo)
7	Common (Go)
8	Do not connect



For more detailed specifications and applications information, contact :

International Headquarters

GAIA Converter - France
ZI de la Morandière
33185 LE HAILLAN - FRANCE
Tel. : + (33)-5-57-92-12-80
Fax : + (33)-5-57-92-12-89

North American Headquarters

GAIA Converter Canada, Inc
4038 Le Corbusier Blvd
LAVAL, QUEBEC - CANADA H7L 5R2
Tel. : (514)-333-3169
Fax : (514)-333-4519

Represented by :