



Industrial DC/DC CONVERTER MGDI-100 Wide Input : 100W POWER

Industrial Grade ■

4:1 & 5:1 Wide Input Single Output Metallic Case - 1.500 VDC Isolation



- Wide input range
- Nominal power up to 100 W
- High efficiency (typ. 88%)
- Soft start
- Galvanic isolation 1.500 VDC according to EN 60950
- Integrated LC input filter
- Permanent short circuit protection
- External synchronisation
- External trim and sense adjustment : -20/+10%
- No optocoupler for high reliability
- RoHS process

1-General

The MGDI-100 wide input series is a full family of DC/DC power modules designed for use in distributed power architecture where variable input voltage and transient are prevalent making them ideal particularly for transportation, railways or high-end industrial applications. These modules use a high frequency fixed switching topology at 260KHz providing excellent reliability, low noise characteristics and high power density. Standard models are available with wide input voltage range of 14-55 and 36-140 volts for 24/36/72/110V batteries. The serie includes single output voltage choices of 2.5, 3.3, 5, 12, 15 and 26 volts (for 24Vdc applications).

The MGDI-100 serie is designed in conformity with safety standards EN60950 and UL1950. All the modules are designed with LC network filters to minimize reflected input current ripple and output voltage ripple according to ease EN55022 and FCC Part 15J standard.

The modules include a soft-start, an input undervoltage and overvoltage lock-out, a permanent short circuit protection, a thermal protection and an output overvoltage protection to ensure efficient module protections. The soft-start allows current limitation and eliminates inrush current during start-up. The short circuit protection completely protects the modules against short-circuits of any duration by a shut-down and restores to normal when the overload is removed.

5

2-Product Selection

Single output model : MGDSI - 100 - -

Input Voltage Range		
	Permanent	Extended Range
G	: 14-55 VDC	55 VDC
Q	: 36-140 VDC	175 VDC

Output
B : 3.3 VDC
C : 5 VDC
E : 12 VDC
F : 15 VDC
26 : 26 VDC (for 24 VDC application)
For lower output voltage below 3.3V please consult factory

2- Product Selection (continued)

Input range	Output	Current	Reference	Options
14-55 VDC	3,3 VDC	20 A	MGDSI-100-G-B	/
14-55 VDC	5 VDC	20 A	MGDSI-100-G-C	/
14-55 VDC	12 VDC	8,25 A	MGDSI-100-G-E	/
14-55 VDC	15 VDC	6,5 A	MGDSI-100-G-F	/
14-55 VDC	26 VDC	3,8 A	MGDSI-100-G-26	/
36-140 VDC	3,3 VDC	20 A	MGDSI-100-Q-B	/
36-140 VDC	5 VDC	20 A	MGDSI-100-Q-C	/
36-140 VDC	12 VDC	8,25 A	MGDSI-100-Q-E	/
36-140 VDC	15 VDC	6,5 A	MGDSI-100-Q-F	/
36-140 VDC	26 VDC	3,8 A	MGDSI-100-Q-26	/

5

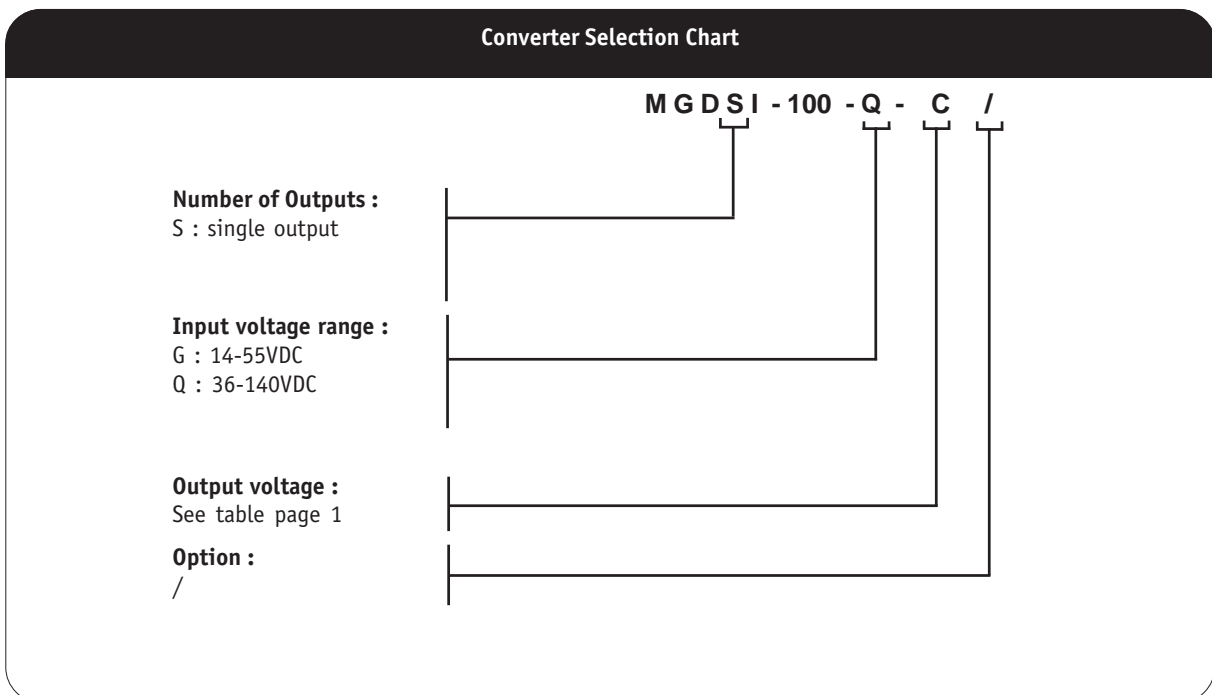

3- Electrical Specifications

Data are valid at +25°C, unless otherwise specified.

Parameter	Conditions	Limit or typical	Units	Single Output MGDSI-100	
				100 - G	100 - Q
Input					
Nominal input voltage	Full temperature range	Nominal	VDC	24	72
Permanent input voltage range (Ui)	Full temperature range	Min. - Max.	VDC	14-55	36-140
Extended permanent input voltage range	Full temperature range (Consult factory)	Min. - Max.	VDC	NA	36-175
Transient input voltage	Full load (Consult factory)	Maximum	VDC/S	60/1	NA
Undervoltage lock-out (UVLO)	Turn-on voltage	Nominal	VDC	13,5 ⁽¹⁾	34
	Turn-off voltage	Nominal	VDC	12,5 ⁽¹⁾	33
Overvoltage lock-out (OVLO)	Turn-on voltage	Nominal	VDC	NA	177
	Turn-off voltage	Nominal	VDC		179
Start up time	Ui nominal within 3 ms Nominal output Full load : resistive	Maximum	ms	30	30
Reflected ripple current	Ui nominal, full load at switching freq. BW = 20MHz	Maximum	mApp	TBD	TBD
No load input power	Ui min. to max. No load	Maximum	W	for Vo<=12Vdc : 10W for Vo>12Vdc : 2W	
Standby input power	Ui min. to max. No load	Maximum	W	1	1
Output					
Output voltage *	Ui min. to max.	Nominal	VDC	3,3	3,3
		Nominal	VDC	5	5
		Nominal	VDC	12	12
		Nominal	VDC	15	15
		Nominal	VDC	26	26
Set Point accuracy *	Ambient temperature : +25°C Ui nominal, 75% load	Maximum	%	+/- 2	+/- 2
Output power **	Full temperature range Ui min. to max.	Maximum	W	see section 10	
Output current **					
3,3V output		Maximum	A	20	20
5V output	Full temperature range	Maximum	A	20	20
12V output	Ui min. to max.	Maximum	A	8,25	8,25
15V output		Maximum	A	6,5	6,5
26V output		Maximum	A	3,8	3,8
Ripple output voltage ***					
3,3V and 5V output	Ui nominal	Maximum	mVpp	50	50
12V output	Full load	Maximum	mVpp	100	100
15V output	BW = 20MHz	Maximum	mVpp	150	150
26V output		Maximum	mVpp	250	250
Output regulation* (Line + load + thermal)	Ui min. to max. 0% to full load	Maximum	%	+/- 1	+/- 1
output Voltage Trim	As a function of output voltage	Minimum	%	80	80
		Maximum	%	110	110
Efficiency	Ui nominal Full load	Typical	%	88	88

Note (1) : A 47KOhm resistance need to be connected across pins Gin and UVLO (see section 12-1)

Note * : These performances are measured with the sense line connected.

Note ** : It is recommended to mount the converter on a heatsink for this test, see section 10 for further details.

Note *** : The ripple output voltage is the periodic AC component imposed on the output voltage, an aperiodic and random component (noise) has also to be considered. This noise can be reduced by adding 1 external decoupling capacitor connected between Gin and Gout. These capacitance should be layed-out as close as possible from the converter. The ripple output voltage is measured by connecting a ceramic chip capacitor Co across Vo and Go pins (C=100µF if Vo<5Vdc C=10µF if Vo>5Vdc)

4- Switching Frequency

Parameter	Conditions	Limit or typical	Specifications
Switching frequency	Full temperature range Ui min. to max. No load to full load	Nominal, fixed	260 KHz

5- Isolation

Parameter	Conditions	Limit or typical	Specifications
Electric strength test voltage	Input to output	Minimum	1.500 VDC / 1 min
Isolation resistance	Input to case 500 VDC Output to case 500 VDC	Minimum Minimum	100 MOhm 100 MOhm

6- Protection Functions

Characteristics	Protection Device	Recovery	Limit or typical	Specifications
Input undervoltage lock-out (UVLO)	Turn-on, turn-off circuit with hysteresis cycle	Automatic recovery	Turn-on nominal Turn-off nominal	See section 3
Input overvoltage lock-out (OVLO)	Turn-on, turn-off circuit with hysteresis cycle	Automatic recovery	Turn-on nominal Turn-off nominal	See section 3
Output current limitation protection (OCP)	Straight line current limitation	Automatic recovery	Nominal	130%
Output overvoltage protection (OVP)	Overvoltage protection limitation	Automatic recovery	Min. - max.	120% +/-5% of output voltage
Over temperature protection (OTP)	Thermal device with hysteresis cycle	Automatic recovery	Nominal	115°C

7- Reliability Data

Characteristics	Conditions	Temperature	Specifications
Mean Time Between Failure (MTBF) According to MIL-HDBK-217F	Ground fixed (Gf)	Case at 40°C Case at 70°C	600.000 Hrs 300.000 Hrs
	Ground mobile (Gm)	Case at 40°C Case at 70°C	300.000 Hrs 150.000 Hrs
Mean Time Between Failure (MTBF) According to IEC-62380-TR	Telecom switchers	/	Consult factory

8- Electromagnetic Interference

Electromagnetic interference requirements according to EN55022 class A and class B can be easily achieved as indicated in the following table :

Electromagnetic Interference according to EN55022		
Conducted noise emission	Configuration	With 4 common mode capacitors $C_c = 10\text{nF}$ and external filter
	Models	Class B
Radiated noise emission	Configuration	With 4 common mode capacitors $C_c = 10\text{ nF}$ and external filter
	Models	Class B

8-1 Module Compliance with EN55022 class A/class B Standard

Electromagnetic interference requirements according to EN55022 class A or class B can be easily achieved by adding an external common mode noise capacitance ($C_c = 10\text{nF}/\text{rated voltage}$ depending on isolation

requirement) and an external filter. The common mode noise capacitance C_c should be layed-out as close as possible from the DC/DC converter. Please consult factory for details.

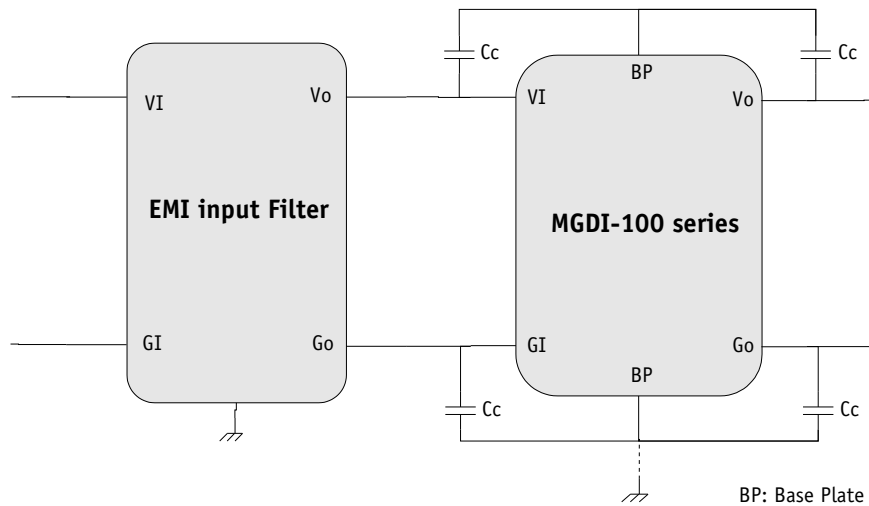

* Note : Value of common mode noise capacitance depends on isolation requirements (typically 10nF/1500V or 10nF/3000V). In case of dielectric strength test in AC mode, adapt the capacitance value in order to be compatible with maximum admissible leakage current.

9- Surge Susceptibility EN61000-4-5 & EN50155

Surge susceptibility requirements according to EN50155, EN61000-4-5 and electromagnetic interference requirements of EN55022 class A can easily be achieved using :

- an input limiter filter : schematics of discret components, to sustain the following surge levels :

Characteristics	Standards	Levels
Spikes Line to line	EN 61000-4-5	Level 4 with 4.000 V waveform 50 μ s, impedance 2 Ohm
	EN 50155	Level 1.800 V waveform 50 μ s, impedance 100 and 5 Ohm Level 8.400 V waveform 0.1 μ s, impedance 100 Ohm
Spikes Line to earth	EN 61000-4-5	Level 4 with 4.000 V waveform 50 μ s, impedance 12 Ohm
	EN 50155	Level 1.800 V waveform 50 μ s, impedance 100 and 5 Ohm Level 8.400 V waveform 0.1 μ s, impedance 100 Ohm

The input limiter filter schematics is given below, please consult design note «Surge filter recommendations for 50W up to 200W modules for details and components description.

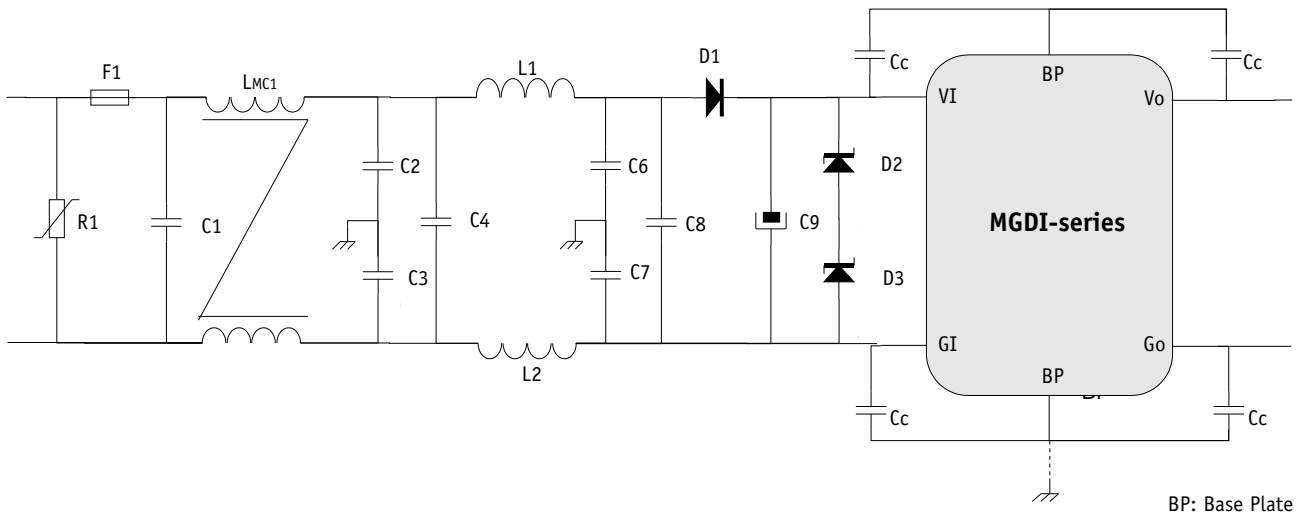

5

10- Thermal Characteristics

Characteristics	Conditions	Limit or typical	Performances
Operating ambient temperature range	Ambient temperature	Minimum Maximum	-40°C see curves
Operating case temperature range at full load	Case temperature	Minimum Maximum	- 40°C see curves
Storage temperature range	Non functioning	Minimum Maximum	- 40°C + 115°C
Thermal resistance	Rth case to ambient in free air natural convection	Typical	6°C /W

The MGDI-100 series maximum **baseplate** temperature must not exceed following values and is a function of output load as described in the following figures :

MGDI-100-G-x Series Maximum Baseplate Temperature Versus Output Power

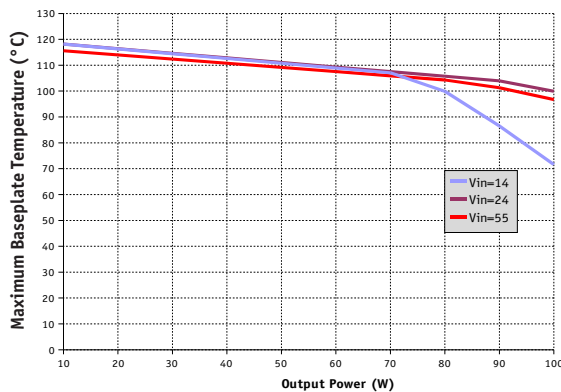

MGDI-100-Q-x Series Maximum Baseplate Temperature Versus Output Power

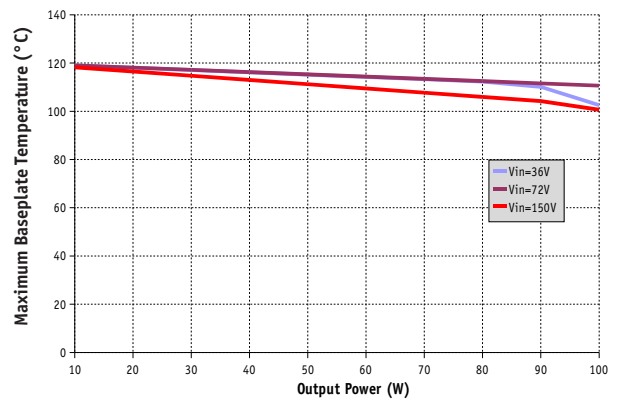

Heat can be removed from the baseplate via three basic mechanisms :

- Radiation transfert : radiation is counting for less than 5% of total heat transfert in majority of case, for this reason the presence of radiant cooling is used as a safety margin and is not considered.
- Conduction transfert : in most of the applications, heat will be conducted from the baseplate into an attached heatsink or heat conducting member; heat is conducted thru the interface.
- Convection transfert : convecting heat transfer into air refers to still air or forced air cooling.

In majority of the applications, heat will be removed from the baseplate either with :

- heatsink,
- forced air cooling,
- both heatsink and forced air cooling.

To calculate a maximum admissible ambient temperature the following method can be used.

Knowing the maximum baseplate temperature $T_{max, baseplate}$ of the module, the power used P_{out} and the efficiency η :

- determine the power dissipated by the module P_{diss} that should be evacuated :

$$P_{diss} = P_{out} / (\eta - 1) \quad (A)$$

- determine the maximum ambient temperature :

$$T_a = T_{max, baseplate} - R_{th}(b-a) \times P_{diss} \quad (B)$$

where $R_{th}(b-a)$ is the thermal resistance from the baseplate to ambient.

This thermal $R_{th}(b-a)$ resistance is the summ of :

- the thermal resistance of baseplate to heatsink ($R_{th}(b-h)$). The interface between baseplate and heatsink can be nothing or a conducting member, a thermal compound, a thermal pad.... The value of $R_{th}(b-h)$ can range from 0.4°C/W for no interface down to 0.1°C/W for a thermal conductive member interface.
- the thermal resistance of heatsink to ambient air ($R_{th}(h-a)$), which is depending of air flow and given by heatsink supplier.

10- Thermal Characteristics (continued)

The table hereafter gives some example of thermal resistance for different heat transfert configurations.

Heat transfert	Thermal resistance heatsink to air Rth(h-a)	Thermal resistance baseplate to heatsink	Global resistance
Free air cooling only	No Heatsink baseplate only : 6°C/W	No need of thermal pad	6°C/W
	Heatsink Aavid Thermalloy 824353B03250 3,9°C/W	Bergquist Silpad* : 0,13°C/W	4,03°C/W
Forced air cooling 200 LFM	No Heatsink baseplate only : 3,8°C/W	No need of thermal pad	3,8°C/W
	Heatsink Aavid Thermalloy 824353B03250 2,1°C/W	Bergquist Silpad* : 0,13°C/W	2,23°C/W
Forced air cooling 400 LFM	No Heatsink baseplate only : 2,63°C/W	No need of thermal pad	2,63°C/W
	Heatsink Aavid Thermalloy 824353B0250 1,5°C/W	Bergquist Silpad* : 0,13°C/W	1,63°C/W
Forced air cooling 1000 LFM	No Heatsink baseplate only : 1,54°C/W	No need of thermal pad	1,54°C/W
	Heatsink Aavid Thermalloy 824353B03250 1°C/W	Bergquist Silpad* : 0,13°C/W	1,13°C/W

Aavid Thermalloy is a heatsink manufacturers. «Silpad» ® is a registered trademark of Bergquist.
 Note* : Silpad performance are for Silpad 400 with pressure conditions of 50 Psi.

The two formulas (A) and (B) described in previous page :

- $P_{diss} = P_{out}(1/\eta - 1)$ (A)
- $T_a = T_{base} - R_{th}(b-a) \times P_{diss}$ (B)

conduct to curves determining the ambient temperature admissible as a function of output power for various heat transfert conditions.

In particular, as example the following typical curves are calculated with :

- no heatsink
- a Aavid Thermalloy heatsink reference 824353B03250 and a Bergquist «Silpad» for various cooling conditions.

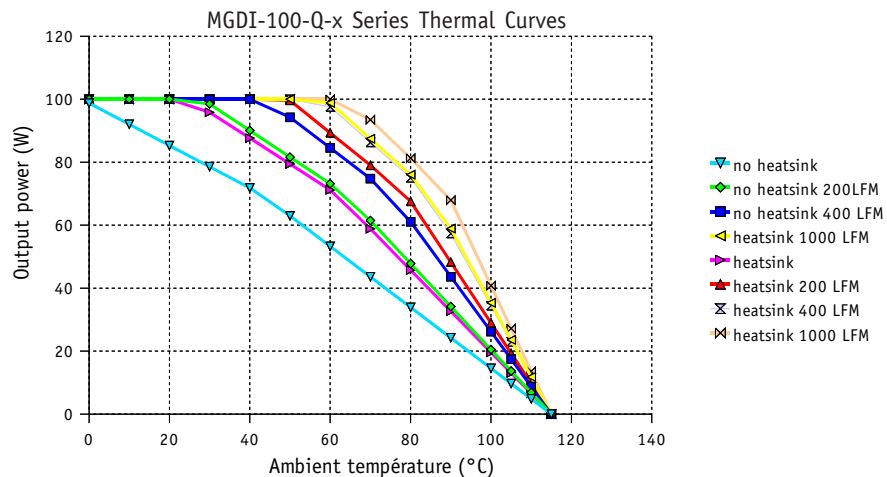
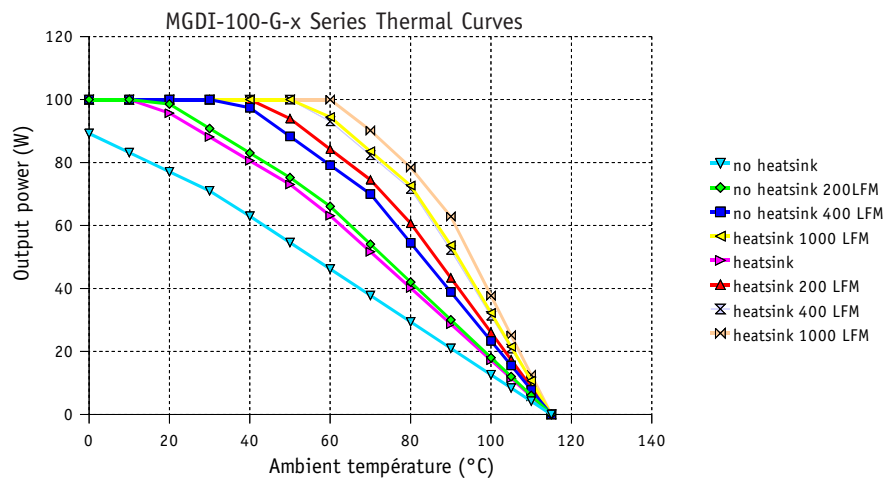

11- Environmental Qualifications

The modules have been subjected to the following environmental qualifications.

Characteristics	Conditions	Severity	Test procedure
Climatic Qualifications			
Life at high temperature	Duration Temperature Status of unit	1.000 Hrs 95°C case unit operating	IEC 68-2-2
Humidity steady	Damp heat Temperature Duration Status of unit	93 % relative humidity 40°C 56 days unit not operating	IEC 68-2-3 Test Ca
Temperature cycling	Number of cycles Temperature change Transfert time Steady state time Status of unit	200 -40°C / +71°C 40 min. 20 min. unit not operating	IEC 68-2-14 Test N
Temperature shock	Number of shocks Temperature change Transfert time Steady state time Status of unit	50 -40°C / +105°C 10 sec. 20 min. unit not operating	IEC 68-2-14 Test Na
Mechanical Qualifications			
Vibration (Sinusoidal)	Number of cycles Frequency : amplitude Frequency : acceleration Amplitude /acceleration Duration Status of unit	10 cycles in each axis 10 to 60 Hz / 0.7 mm 60 to 2000 Hz / 10 g 0.7 mm/10 g 2h 30 min. per axis unit not operating	IEC 68-2-6 Test Fc
Shock (Half sinus)	Number of shocks Peak acceleration Duration Shock form Status of unit	3 shocks in each axis 100 g 6 ms 1/2 sinusoidal unit not operating	IEC 68-2-27 Test Ea
Bump (Half sinus)	Number of bumps Peak acceleration Duration Status of unit	2000 bumps in each axis 25 g 6 ms unit not operating	IEC 68-2-29 Test Eb
Electrical Immunity Qualifications			
Electrical discharge susceptibility	Number of discharges Air discharge level Contact discharge level Air discharge level Contact discharge level	10 positive & 10 negative discharges 4 kV : sanction A 2 Kk : sanction A 8 Kk : sanction B 4 kV : sanction B	EN55082-2 with : EN61000-4-2 IEC 801-2
Electrical field susceptibility	Antenna position Electromagnetic field Wave form signal Frequency range	at 1 m 10 V/m AM 80%, 1 kHz 26 MHz to 1 GHz	EN55082-2 with : EN61000-4-3 IEC801-3
Electrical fast transient susceptibility	Burst form Wave form signal Impedance Level 1 Level 3	5/50 ns 5 kHz with 15 ms burst duration period 300 ms 50 Ohm 0,5 kV : sanction A 2 kV : sanction B	EN55082-2 with : EN61000-4-4 IEC801-4
Surge Susceptibility	Surge form Impedance Level 4	1,2/50 µs 2 Ohm 4 kV : with transient protection (see section surge)	EN61000-4-5 EN50155

12- Description of Protections

The MGDI-100 series include 5 types of protection devices.

12-1 Input Undervoltage Lockout (UVLO) and Overvoltage Lockout (OVLO)

12-1-1 Undervoltage Lockout (UVLO)

An input undervoltage protection will inhibit the module when input voltage drops below the lock-out turn-off threshold (see section 3 for value) and restores to normal operation automatically when the input voltage rises the lock-out turn-on threshold.

The input undervoltage lock-out threshold (UVLO) can be trimmed up by connecting a resistor between UVLO and Gi pins. This resistance can be calculated as follow :

$$R_{UVLO} = \frac{a \times (1 + b - n)}{(n - 1)} \quad \text{where } n = \frac{UVLO_{trim}}{UVLO_{threshold}}$$

	Input G	Input Q
a	NA	1000
b	NA	6.55

12-1-2 Overvoltage Lockout (OVLO)

An input overvoltage protection will inhibit the module when input voltage reaches the overvoltage lockout turn-off threshold (see section 3 for value) and restores to normal operation automatically when the input voltage drops below the overvoltage Lockout turn on threshold.

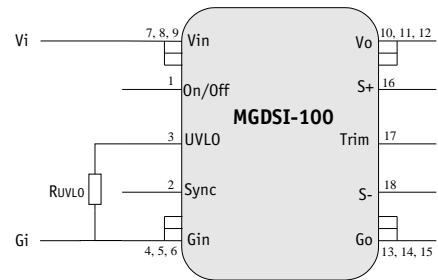
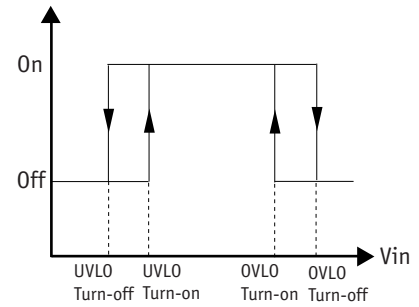

12-2 Output Over Current Protection (OCP)

The MGDI-100 Series incorporates a straight line current limit and protection circuit. When the output current reaches 130% of its full-rated current (Icurrent limit), the output voltage decreases down to 75% of nominal output voltage. Below this threshold the converter falls in hiccup mode by testing periodically if an overload is applied. The module restart automatically to normal operation when overcurrent is removed.

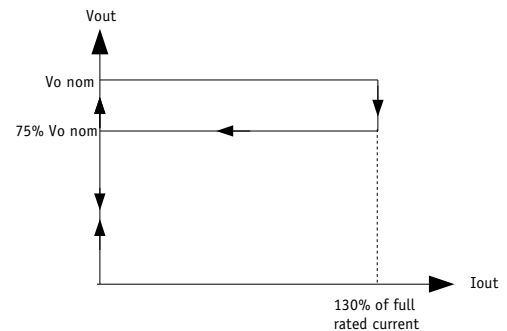

12-3 Output Overvoltage Protection (OVP)

The MGDI-100 series has an internal overvoltage protection circuit that monitors the voltage across the output power terminals. It is designed to limit the converter at 120% (+/-5%) of output voltage.

12-4 Over Temperature Protection (OTP)

A thermal protection device adjusted at 115°C (+/-5%) internal temperature with 10°C hysteresis cycle will inhibit the module as long as the overheat is present and restores to normal operation automatically when overheat is removed. The efficiency of the OTP function is warranty with the module mounted on a heatsink.

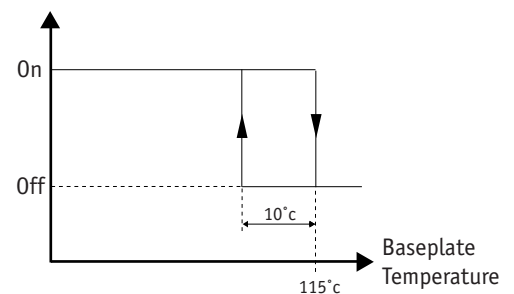

13- Description of Functions

13-1 Trim Function

The output voltage V_o may be trimmed in a range of 80%/110% of the nominal output voltage via a single external trimpot or fixed resistor.

Trim Up Function

Do not attempt to trim the module higher than 110% of nominal output voltage as the overvoltage protection may occur.

Also do not exceed the maximum rated output power when the module is trimmed up.

The trim up resistor must be connected to S+ pin.

The trim up resistance must be calculated with the following formula :

$$R_u = \frac{R_1 \times (V_o - V_{ref}) \times V_{o_{nom}}}{(V_o - V_{o_{nom}}) \times V_{ref}} - R_1 - R_2$$

Trim Down Function

Do not trim down more than -20% of nominal output voltage otherwise the module may turn off.

The available output power is reduced by the same percentage that output voltage is trimmed down.

The trim down resistor must be connected to S- pin.

The trim down resistance must be calculated with the following formula :

$$R_d = \frac{(R_2 + R_1) \times V_o - R_2 \times V_{o_{nom}}}{V_{o_{nom}} - V_o}$$

Trim via a voltage

The output voltage is given by the following formula :

$$V_o = \left[1 + \frac{R_1}{(R_1 + R_2)} \times \frac{(V_{cont} - 1)}{V_{ref}} \right] \times V_{nom}$$

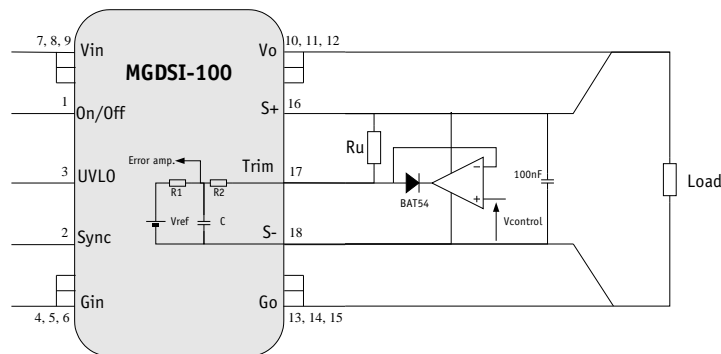
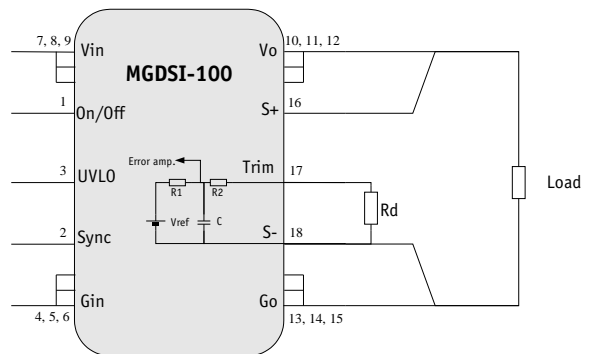
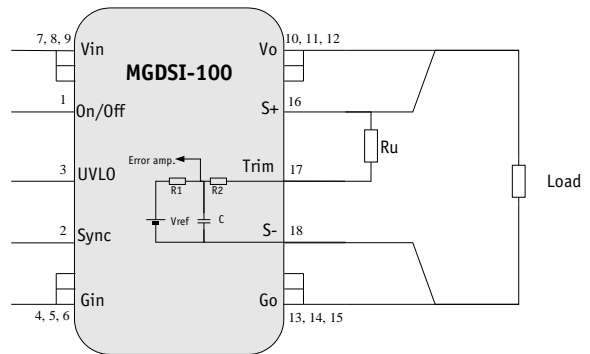

Parameter	Unit	Min.	Typ.	Max.
Trim reference Vref	Vdc	2,45	2,5	2,55
Resistor R1	Ohm	/	39K	/
Resistor R2	Ohm	/	270	/
Trim capacitor C	nF	/	10	/

13- Description of Functions (continued)

13-2 Sense Function

If the load is separated from the output by any line length, some of these performance characteristics will be degraded at the load terminals by an amount proportional to the impedance of the load leads. Sense connections enable to compensate the line drop at a maximum of 10% of output voltage. The overvoltage protection will be activated if remote sense tries to boost output voltage above 120% of nominal output voltage. Connection is described in figure herein.

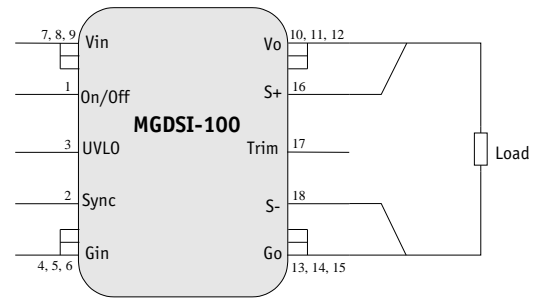

13-3 On/Off Function

The control pin 1 (On/Off) can be used for applications requiring On/Off operation. This may be done with an open collector transistor, a switch, a relay or an optocoupler. Several converters may be disabled with a single switch by connecting all On/Off pins together.

- The converter is disabled by pulling low the pin 1.
- No connection or high impedance on pin 1 enables the converter.

By releasing the On/Off function, the converter will restart within the start up time specifications given in table section 3

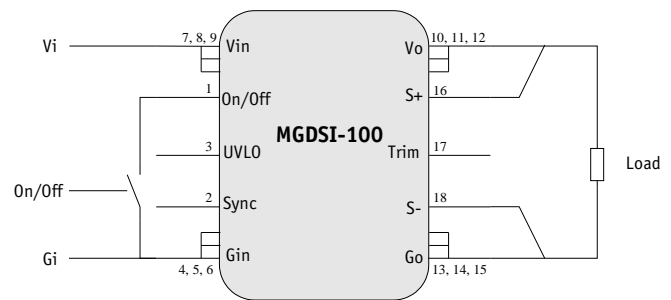

Parameter	Unit	Min.	Typ.	Max.	Notes, conditions
On/Off module enable voltage	Vdc	3.5	/	5	Open, the switch must not sink more than 100µA
On/Off module disable voltage	Vdc	0	/	0.5	The switch must be able to sink 1mA
On/Off alarm level	Vdc	0	/	0.5	OTP faulty module
On/Off module enable delay	ms	/	/	30	The module restarts with the same delay after alarm mode removed
On/Off module disable delay	µs	/	/	100	Vi nominal, full load

13-4 Synchronization Function

An external clock with pulse signals can be used to lock one or more converters. The external clock signal should have a frequency range from 270KHz to 300KHz, a low level below 0,5V a high level of 4V (+/-0.5V), a rise time of 30 ns max., a fall time of 100ns max., and a pulse width of 300 to 500 ns. Several converters can be synchronized by connecting their Sync pin together.

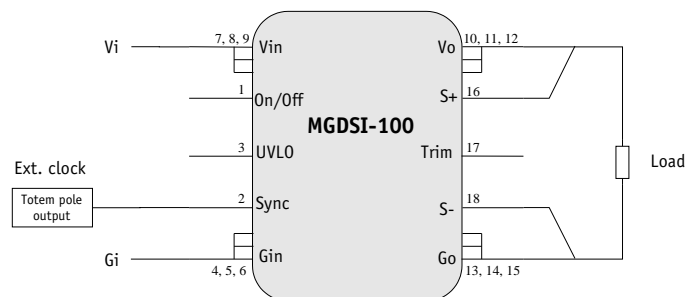
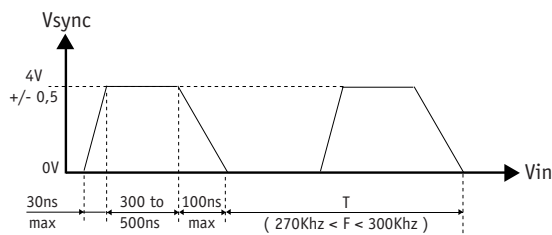

14- Application Notes

14-1 Input to Output Impedance

The MGDI-100 converters have been designed to be stable with no external capacitors when used in low inductance input and output circuits.

However, in many applications, the inductance associated with the distribution from the power source to the input of the converter can affect the stability of the converter. The addition of a $C_{in}=10\mu\text{F}$ electrolytic capacitor with an $\text{ESR} < 1 \text{ Ohm}$ across the input helps ensure stability of the converter.

In many applications, the user has also to use decoupling capacitance at the load. The addition of a decoupling ceramic chip capacitor C_o ($C_o=10\mu\text{F}$ if $V_o>5\text{Vdc}$ or $C_o=100\mu\text{F}$ if $V_o\leq 5\text{Vdc}$) across the output and placed close to the converter allows to achieve the output voltage ripple specified in the table page 3.

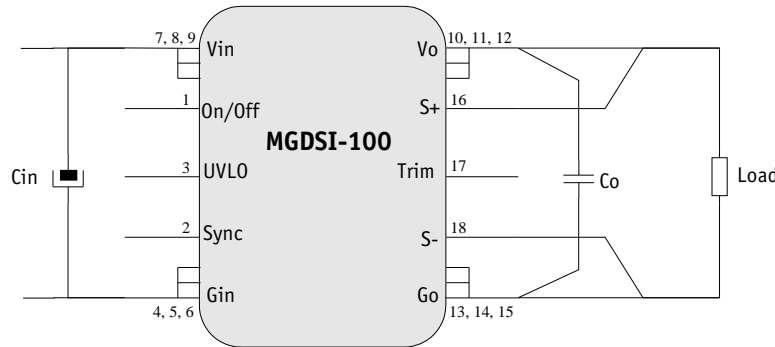

14-2 Synchronization of Modules

The MGDI-100 series provides a synchronization function through the pin 2 (Synchro) to enable automatic synchronization between several converters.

If several converters are used, they lock themselves into the highest switching frequency.

The synchronization signal available on pin 2 is referenced to ground in (Gi).

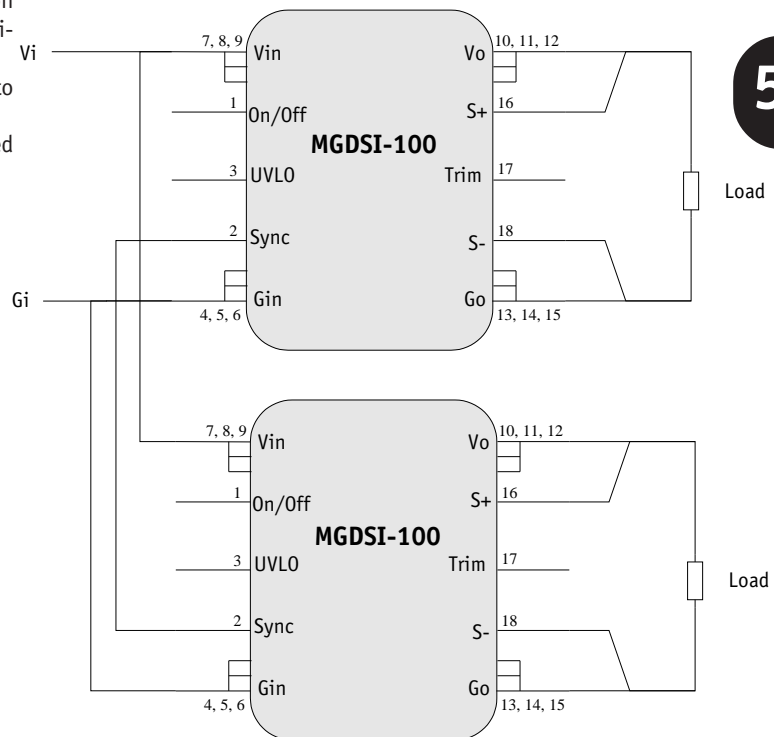

14-3 Connection of Modules in Series

The output of single output units can be connected in series without any precautions to provide higher output voltage level.

Nevertheless, GAIA Converter recommends to protect each individual output by a low power shottky diode rated with the maximum current of the converter to avoid reverse polarity at any output.

Reverse polarity may occur at start up if the output voltages do not rise at the same time.

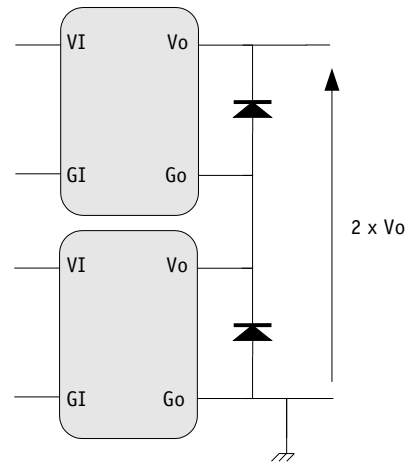

15- PCB Mounting Specifications

The MGDI-100 series has been designed for low profile applications.

Two levels of mounting can be designed :

- On-board mounting with 12,5 mm height
- In-board mounting with 10,5 mm height and PCB hole design on the mother board

On-board Mounting



In-board Mounting



16- Dimensions

Dimension are given in mm (inches). Tolerance : +/- 0,2 mm (+/- 0.01 ") unless otherwise indicated.
Weight : 65 grams (2.30 Ozs) max.

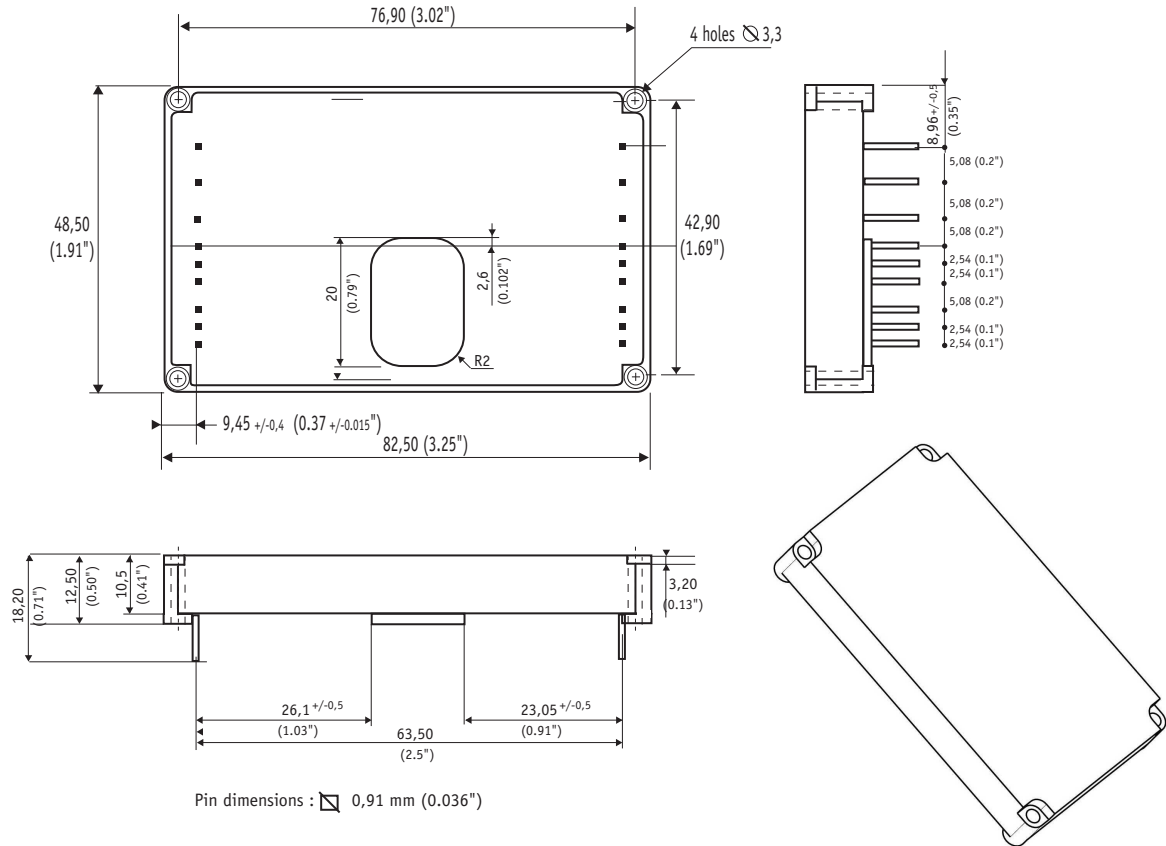

17- Materials

Case : Metallic black anodized coating.

Pins : Plated with pure matte tin over nickel underplate.

18- Product Marking

Upper face : Company logo, location of manufacturing.

Side face : Module reference, option, date code : year and week of manufacturing.

19- Connections

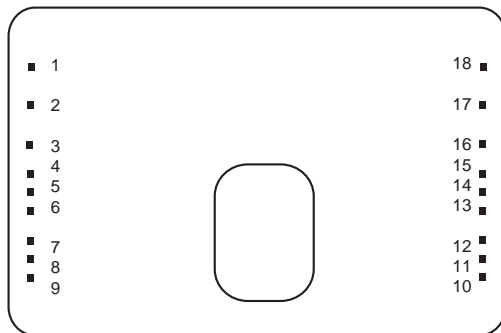

Bottom view

Pin	Single
1	On / Off
2	Synchro (Sync)
3	UVLO
4, 5, 6	- Input (Gi)
7, 8, 9	+ Input (Vi)
10, 11, 12	Output (Vo)
13, 14, 15	Common (Go)
16	Sense +
17	Trim
18	Sense -



For more detailed specifications and applications information, contact :

International Headquarters

GAIA Converter - France
ZI de la Morandière
33185 LE HAILLAN - FRANCE
Tel. : + (33)-5-57-92-12-80
Fax : + (33)-5-57-92-12-89

North American Headquarters

GAIA Converter Canada, Inc
4038 Le Corbusier Blvd
LAVAL, QUEBEC - CANADA H7L 5R2
Tel. : (514)-333-3169
Fax : (514)-333-4519

Represented by :