



# Hi-Rel DC/DC CONVERTER MGDM-75 : 75W POWER

Hi-Rel  
Grade ■■

**3:1 High Input Voltage : 155 - 480 VDC**  
**Single Output**  
**Metallic case - 2.200 VDC Isolation**



4

- Wide input range 155-480 Vdc
- 270Vdc input compliant with MIL-STD-704E/F
- Industry standard quarter brick package
- Power up to 75 W
- Wide temperature range : -40/+105°C baseplate
- High efficiency (up to 92%)
- Soft start
- Galvanic isolation 2.200 VDC
- Integrated input filter
- Synchronizable
- Parallelable in option
- No load to full load operation
- Fully protected by independant protection
  - Undervoltage lock-out
  - Overvoltage protection
  - Current limitation protection
  - Overtemperature protection
- No optocoupler for high reliability
- RoHS process

## 1-General

The MGDM-75 high input series is a complete line of high density wide input range DC/DC power modules designed for aerospace, military and high-end industrial applications. These modules use a patented fixed switching topology at 500 KHz providing wide input range, low noise characteristics and high power density. Standard models are available with wide input voltage range of 155-480 volts. The series include single output voltage of 3.3, 5, 12, 15, 26 volts. The MGDM-75 high input series include synchronization, parallelable with load sharing, trim and sense functions. The synchronization function allows to synchronize more than one converter to one frequency or an external source frequency. The parallelable function allows increased power with a true N+1 redundancy.

All the modules are designed with LC network filters to minimize reflected input current ripple and output voltage ripple.

The modules have totally independant security functions including input undervoltage lock-out, output overvoltage protection, output current limitation protection, and temperature protection. Additionnally a soft-start function allows current limitation and eliminates inrush current during start-up.

The design has been carried out with surface mount components, and is manufactured in a fully automated process to guarantee high quality. The modules are potted with a bi-component thermal conductive compound to ensure optimum power dissipation under harsh environmental conditions.

## 2-Product Selection

Single output model : MGDS - 75 -  -  /  -

Input Voltage Range
Permanent
S : 155-480 VDC

Output
B : 3.3 VDC
C : 5 VDC
E : 12 VDC
F : 15 VDC
26 : 26 VDC

### Options :

- /T : option for -55°C start up operating temperature
- /S : option for screening and serialization
- /P : option for parallelable operation

### Suffix :

nothing : RoHS process

## 2- Product Selection (continued)

Input range	Output	Current	Reference	Options	Suffix
155-480 VDC	3.3 VDC	15 A	MGDS-75-S-B	/T, /S, /P	/
155-480 VDC	5 VDC	15 A	MGDS-75-S-C	/T, /S, /P	/
155-480 VDC	12 VDC	6,25 A	MGDS-75-S-E	/T, /S, /P	/
155-480 VDC	15 VDC	5 A	MGDS-75-S-F	/T, /S, /P	/
155-480 VDC	26 VDC	2,85 A	MGDS-75-S-26	/T, /S, /P	/

4

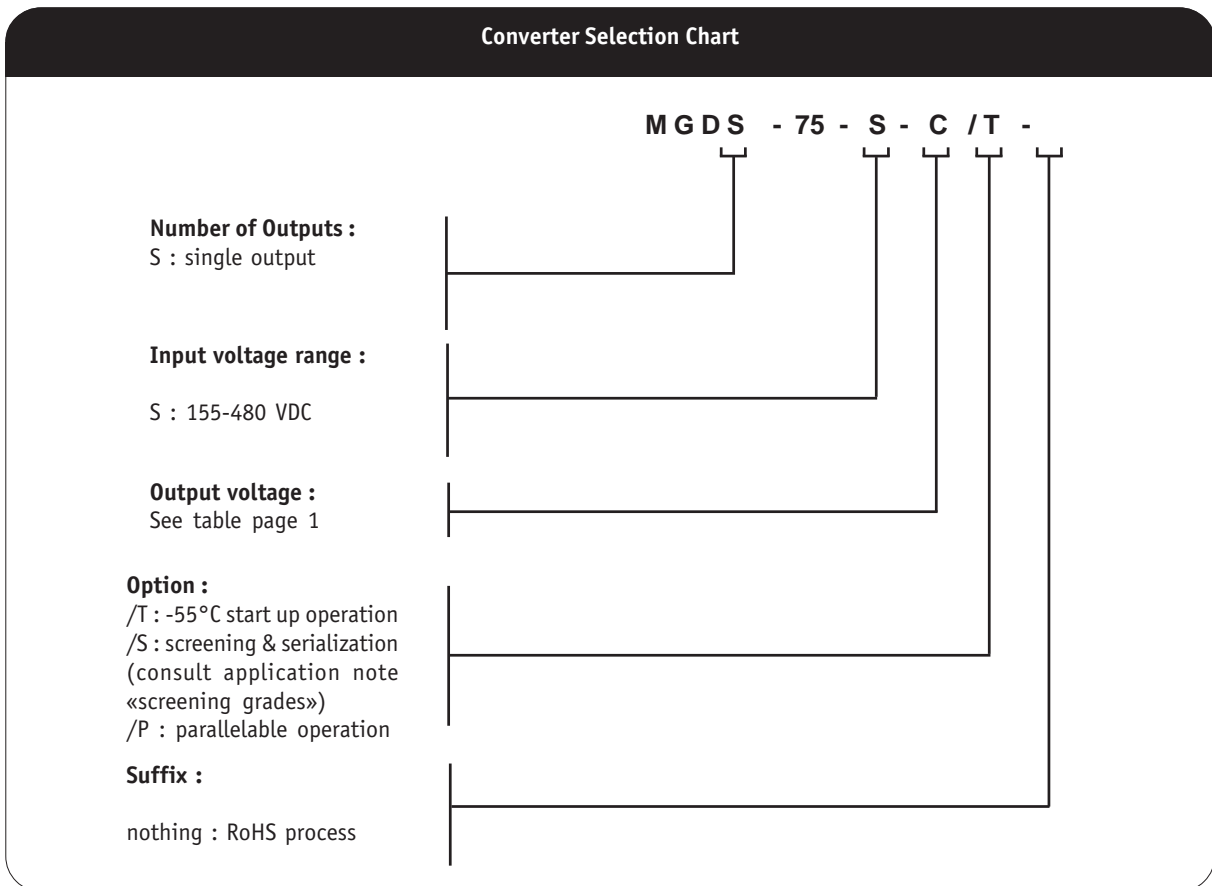

### 3- Electrical Specifications

Data are valid at +25°C, unless otherwise specified.

Parameter	Conditions	Limit or typical	Units	MGDS-75 - S
<b>Input</b>				
Nominal input voltage	Full temperature range	Nominal	VDC	270
Permanent input voltage range (Ui)	Full temperature range	Min. - Max.	VDC	155 - 480
Undervoltage lock-out (UVLO)	Turn-on voltage	Maximum	VDC	155
Start up time	Ui nominal Nominal output Full load : resistive	Maximum	ms	30
Reflected ripple current****	Ui nominal, full load BW = 20MHz	Maximum	% of input current	10
Input current in short circuit mode (Average)	Ui nominal Short-circuit	Typical	mA	20
No load input current	Ui nominal No load	Maximum	mA	15
Input current in inhibit mode	Ui nominal Inhibit	Maximum	mA	2
<b>Output</b>				
Output voltage *	Ui min. to max.	Nominal	VDC	3.3
		Nominal	VDC	5
		Nominal	VDC	12
		Nominal	VDC	15
		Nominal	VDC	26
Set Point accuracy *	Ambient temperature : +25°C Ui nominal, 75% load	Maximum	%	+/- 2
Output power **	At 105°C baseplate Ui min. to max.	Maximum	W	75
Output current **	Full temperature range Ui min. to max.	Maximum	A	15
3.3V output		Maximum	A	15
5V output		Maximum	A	6,25
12V output		Maximum	A	5
15V output		Maximum	A	2,85
26V output				
Ripple output voltage ***	Ui nominal Full load BW = 20MHz	Typical	mVpp	50
3.3V, 5V output			mVpp	150
12V, 15V output			mVpp	250
26V output				
Output regulation * (Line + load + thermal)	Ui min. to max. 0% to full load	Maximum	%	+/- 1
Output Voltage Trim	As function of output voltage	Minimum	%	90 *
		Maximum	%	110
Efficiency	Ui nominal Full load	Typical	%	90

Note \* : These performances are measured with the sense line connected..

Note \*\* : It is recommended to mount the converter on a heatsink for this test, see section 9-3 and 9-9 for further details.

Note \*\*\* : The ripple output voltage is the periodic AC component imposed on the output voltage, an aperiodic and random component (noise) has also to be considered. This noise can be reduced by adding 4 external decoupling capacitors connected between inputs and case and between outputs and case. These capacitance should be layed-out as close as possible from the converter. Please refer to page 8 for more details.

Note \*\*\*\* : These performances are with 10µF input capacitor.

## 4- Switching Frequency

Parameter	Conditions	Limit or typical	Specifications
Switching frequency	Full temperature range Ui min. to max. No load to full load	Nominal, fixed	500 KHz

## 5- Isolation

Parameter	Conditions	Limit or typical	Specifications
Electric strength test voltage	Input to output	Minimum	2.200 VDC / 1 min
	Input to case	Minimum	2.200 VDC / 1 min
	Output to case	Minimum	2.200 VDC / 1 min
Isolation resistance	500 VDC	Minimum	100 MOhm

## 6- Protection Functions

Characteristics	Protection Device	Recovery	Limit or typical	Specifications
Input undervoltage lock-out (UVLO)	Turn-on, turn-off circuit with hysteresis cycle	Automatic recovery	Turn-on nominal Turn-off nominal	see section 3
Output current limitation protection (OCP)	Straight line current limitation	Automatic recovery	Nominal	120% of output current
Output overvoltage protection (OVP)	Overvoltage protection device with latch-up	Automatic recovery	Nominal	120% of output voltage
Over temperature protection (OTP)	Thermal device with hysteresis cycle	Automatic recovery	Nominal	120°C

## 7- Reliability Data

Characteristics	Conditions	Temperature	Specifications
Mean Time Between Failure (MTBF) According to MIL-HDBK-217F	Ground fixed (Gf)	Case at 40°C Case at 85°C	consult factory
	Airborne, Inhabited, Cargo (AIC)	Case at 40°C Case at 85°C	consult factory
Mean Time Between Failure (MTBF) According to IEC-62380-TR	Avionics Military Cargo	/	Consult factory

## 8- Electromagnetic Interference

Electromagnetic Interference requirements according to MIL-STD-461C/D/E standards can be easily achieved as indicated in the following section. The following table resumes the different sections covered by these standards.

Standard Requirements	MIL-STD-461C Standard	MIL-STD-461D/E Standard	Compliance with GAIA Converter Module & common mode capacitance
<b>Conducted emission (CE) :</b> Low frequency High frequency	CE 01 CE 03	CE 101 CE 102	compliant module stand-alone compliant with additional filter
<b>Conducted susceptibility (CS) :</b> Low frequency High frequency	CS 01 CS 02	CS 101 CS114	compliant with additional filter compliant with additional filter
<b>Radiated emission (RE) :</b> Magnetic field Electrical field	RE 01 RE 02	RE 101 RE 102	compliant with additional filter compliant with additional filter
<b>Radiated susceptibility (RS) :</b> Magnetic field Electrical field	RS 01 RS 03	RS 101 RS 103	compliant with additional filter compliant with additional filter

### 9-1 Module Compliance with MIL-STD-461C Standard

To meet MIL-STD-461C requirements and in particular CE03 requirement, Gaïa Converter recommends the use of the following front filter together with 4 external decoupling capacitors connected between inputs and case and between outputs and case. Please consult MIL-STD-461C EMI filter design note for further details.

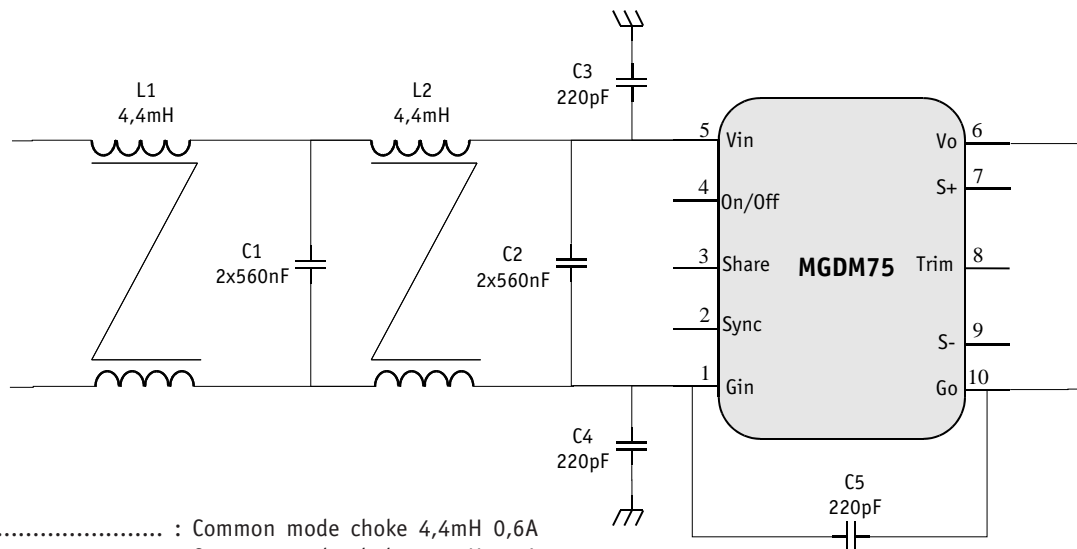

- L1 ..... : Common mode choke 4,4mH 0,6A
- L2 ..... : Common mode choke 4,4mH 0,6A
- C1 ..... : 2 x ceramic capacitors 560nF
- C2 ..... : 2 x ceramic capacitors 560nF
- C3, C4, C5\* ..... : Low ESR and ESL ceramic capacitor 220pF

(\*) Must be placed as close as possible to the converter in order to reduce the path length or the connections to the pins and the baseplate.

## 9- Thermal Characteristics

Characteristics	Conditions	Limit or typical	Performances
Operating ambient temperature range at full load	Ambient temperature *	Minimum Maximum	- 40°C see below
Baseplate temperature	Base plate temperature	Minimum Maximum	- 40°C see curves below
Storage temperature range	Non fonctionning	Minimum Maximum	- 55°C + 125°C
Thermal resistance	Baseplate to ambient Rth(b-a) free air	Typical	11°C/W

Note \* : The MGDM-75 high input series maximum **baseplate** temperature must not exceed the following values and is a function of output load and input power as described in the following figure :

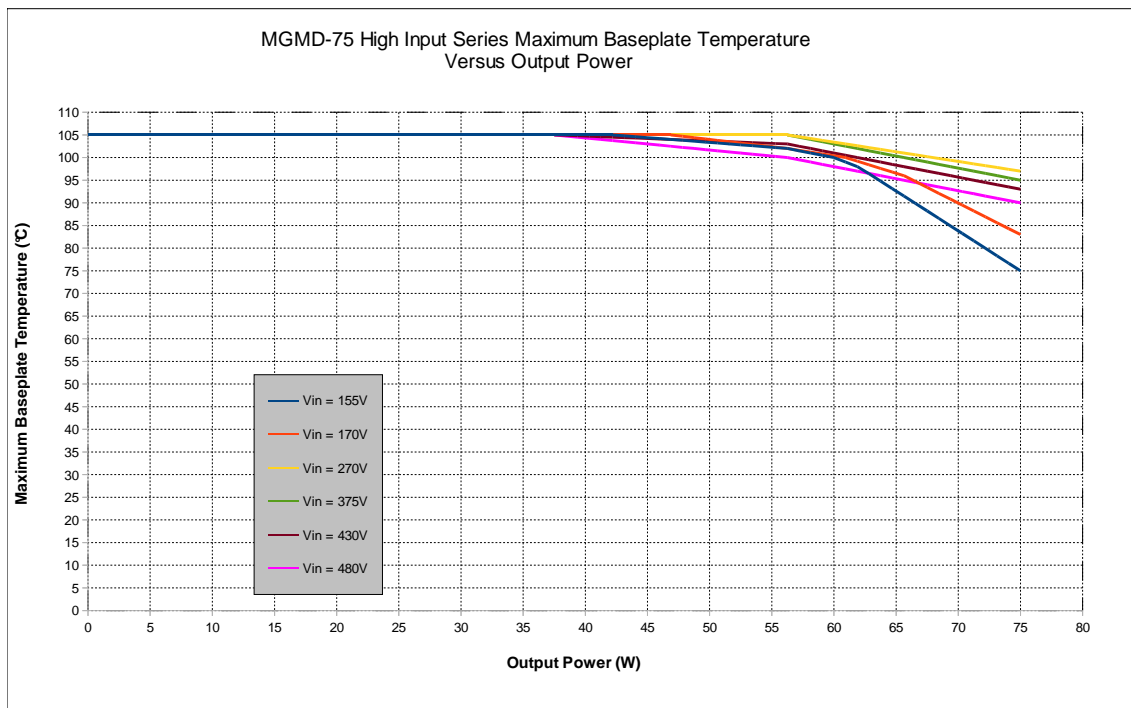

The MGDM-75 high input series maximum baseplate temperature at full load must not exceed value in the graph.

Heat can be removed from the module via three basic mechanisms :

- Radiation transfer : radiation is counting for less than 5% of total heat transfer in most cases, for this reason the presence of radiant cooling is used as a safety margin and is not considered.
- Conduction transfer : in most applications, heat will be drained from the casing into an attached heatsink or heat conducting member; heat is conducted through the interface.
- Convection transfer : convecting heat transfer into air refers to still air or forced air cooling.

In majority of the applications, heat will be removed from the module either with :

- heatsink,
- forced air cooling,
- both heatsink and forced air cooling.

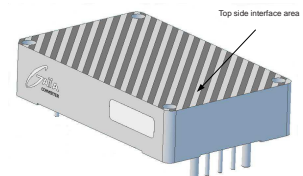

The MGDM-75 series has been designed in such a manner that cooling is achieved by conduction transfer using defined interface area on the top of the casing. This area is shown in the figure herein.

## 9- Thermal Characteristics (continued)

Heat must be conducted from the casing into an attached heat sink or heat conducting member through the top side interface areas.

Thermal compound or a thermal pad should be used to fill surface irregularities of this area.

To calculate a maximum admissible ambient temperature the following method can be used. Knowing the maximum baseplate temperature of the module  $T_{case} = 105^{\circ}\text{C}$ , the power used  $P_{out}$ , and the efficiency  $\eta$  :

- determine the power dissipated by the module  $P_{diss}$  :

$$P_{DISS} = P_{OUT} \cdot \left( \frac{1}{\eta} - 1 \right)$$

- determine the maximum ambient temperature :

$$T_a = 105 - Rth_{b-A} \cdot P_{DISS}$$

where  $Rth_{b-A}$  is the thermal resistance from baseplate to ambient.

This thermal resistance  $Rth_{b-A}$  is the sum of :

- the thermal resistance of baseplate to heatsink ( $Rth_{b-H}$ ). The interface between baseplate and heatsink should be a thermally conductive part such as a thermal compound or a thermal pad.... The value of  $Rth_{b-H}$  can range from  $0.4^{\circ}\text{C/W}$  for no interface down to  $0.1^{\circ}\text{C/W}$  for a thermal conductive part.
- the thermal resistance of heatsink to ambient air ( $Rth_{H-A}$ ), which is depending of air flow and given by heatsink supplier.

$$Rth_{b-A} = Rth_{b-H} + Rth_{H-A}$$

## 10- Environmental Qualifications

The modules have been subjected to the following environmental qualifications.

Characteristics	Conditions	Severity	Test procedure
<b>Climatic Qualifications</b>			
Life at high temperature	Duration Temperature / status of unit	Test D : 1.000 Hrs @ 125°C ambient, unit not operating	MIL-STD-202G Method 108A
Altitude	Altitude level C Duration Climb up Stabilization Status of unit	40.000 ft@-55°C 30 min. 1.000 ft/min to 70.000 f@-55°C, 30 min. unit operating	MIL-STD-810G Method 500.5
Humidity cyclic	Number of cycle Cycle duration Relative humidity variation Temperature variation Status of unit	10 Cycle I : 24 Hrs 60 % to 88 % 31°C to 41°C unit not operating	MIL-STD-810G Method 507.5
Humidity steady	Damp heat Temperature Duration Status of unit	93 % relative humidity 40°C 56 days unit not operating	MIL-STD-202G Method 103B
Salt atmosphere	Temperature Concentration NaCl Duration Status of unit	35°C 5 % 48 Hrs unit not operating	MIL-STD-810G Method 509.5
Temperature cycling	Number of cycles Temperature change Transfert time Steady state time Status of unit	200 -40°C / +85°C 40 min. 20 min. unit operating	MIL-STD-202A Method 102A
Temperature shock	Number of shocks Temperature change Transfert time Steady state time Status of unit	100 -55°C / +105°C 10 sec. 20 min. unit not operating	MIL-STD-202G Method 107G
<b>Mechanical Qualifications</b>			
Vibration (Sinusoidal)	Number of cycles Frequency / amplitude Frequency / acceleration Duration Status of unit	10 cycles in each axis 10 to 60 Hz / 0.7 mm 60 to 2000 Hz / 10 g 2h 30 min. per axis unit not operating	MIL-STD-810G Method 514.6
Shock (Half sinus)	Number of shocks Peak acceleration Duration Shock form Status of unit	3 shocks in each axis 100 g 6 ms 1/2 sinusoidal unit not operating	MIL-STD-810G Method 516.6
Bump (Half sinus)	Number of bumps Peak acceleration Duration Status of unit	2000 Bumps in each axis 40 g 6 ms unit not operating	MIL-STD-810G Method 516.6

## 11- Description of Protections

The MGDM-75 high input series include 4 types of protection devices.

### 11-1 Input Undervoltage Lockout (UVLO)

An undervoltage protection is implemented to switch off the converter as long as the input voltage has not reached the UVLO turn-on threshold (see section 3 for value) which is the minimum input voltage required to operate without damaging the converter.

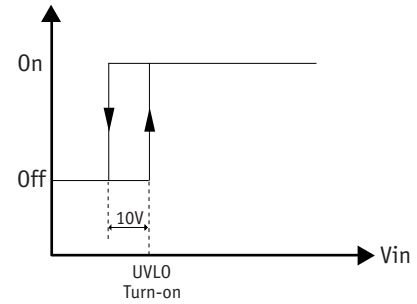

### 11-2 Output Over Current Protection (OCP)

The MGDM-75 high input series incorporates a foldback current limit and protection circuit. When the output current reaches 120% of its full-rated current, the output voltage falls and output current drops along the foldback line as described in the figure herein. The module falls in hiccup mode and automatically resumes to normal operation when the overcurrent is removed.

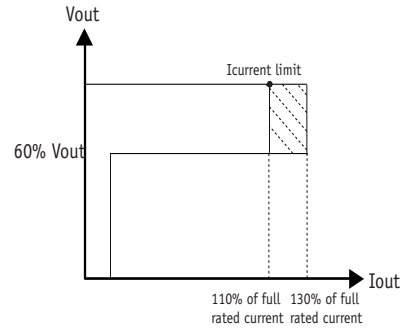

### 11-3 Output Overvoltage Protection (OVP)

The MGDM-75 high input series has an internal overvoltage protection circuit that monitors the voltage across the output power terminals. It is designed to limit the converter at 120% (+/-5%) of output voltage.

### 11-4 Over Temperature Protection (OTP)

A thermal protection device adjusted at 120°C (+/-5%) internal temperature with 10°C hysteresis cycle will inhibit the module as long as the overheat is present and will restore to normal operation automatically once the overheat is removed. The effectiveness of the OTP function is warranty with the module mounted on a heatsink.

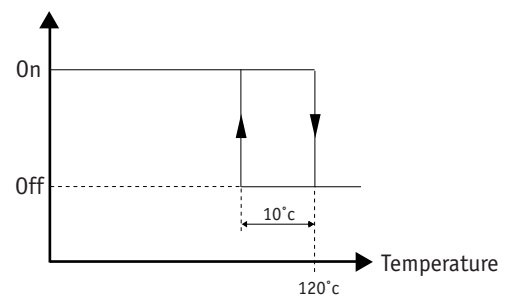

## 12- Description of Functions

### 12-1 Trim Function

The output voltage  $V_o$  may be trimmed in a range of 90% to 110% of the nominal output voltage via an external trimmer or a fixed resistor.

#### Trim Up Function

Do not trim the module above 110% of nominal output voltage as the overvoltage protection will trigger. Also do not exceed the maximum rated output power when the module is trimmed up. The trim up resistor must be connected to the S+ pin. The trim up resistor must be calculated with the following formula :

$$R_u = \frac{R1 \cdot (V_o - V_{ref}) \cdot V_{o_{nom}}}{(V_o - V_{o_{nom}}) \cdot V_{ref}} - R1 - R2$$

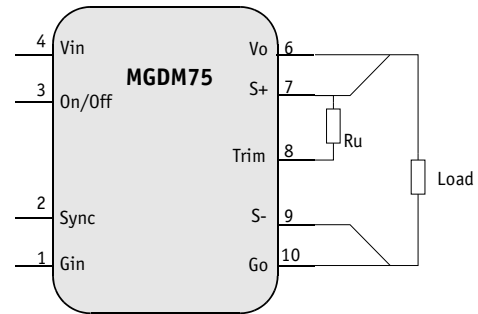

#### Trim Down Function

Do not trim down below 90% of nominal output voltage. The available output power is reduced by the same percentage that output voltage is trimmed down. The trim down resistor must be connected to S- pin. The trim down resistor must be calculated with the following formula :

$$R_d = \frac{(R1 + R2) \cdot V_o - (R2 \cdot V_{o_{nom}})}{V_{o_{nom}} - V_o}$$

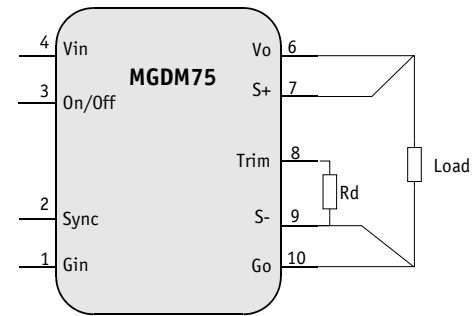

#### Trim via a voltage

The output voltage is given by the following formula :

$$V_o = \left(1 + \frac{R1}{R1 + R2} \cdot \left(\frac{V_{cont}}{V_{ref}} - 1\right)\right) \cdot V_{o_{nom}}$$

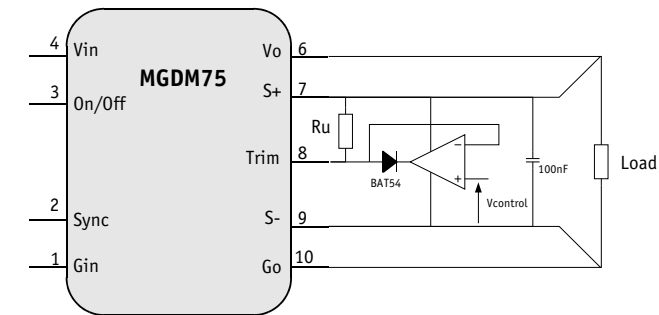

#### Trim resistor values calculated automatically:

On-line calculators for trim resistor values are available on the Gaia converter website at : <http://www.gaia-converter.com/calculator>.

Parameter	Unit	Min.	Typ.	Max.
Trim reference	Vdc	2,45	2,5	2,55
Resistor R1	Ohm	/	39K	/
Resistor R2	Ohm	/	270	/

## 12- Description of Functions (continued)

### 12-2 Sense Function

If the load is separated from the output by any line length, some of these performance characteristics will be degraded at the load terminals by an amount proportional to the impedance of the load leads. Sense connections enable to compensate the line drop at a maximum of +/-10% of output voltage. The overvoltage protection will be activated and module will shut down if remote sense tries to boost output voltage above 110% of nominal output voltage. Connection is described in figure herein.

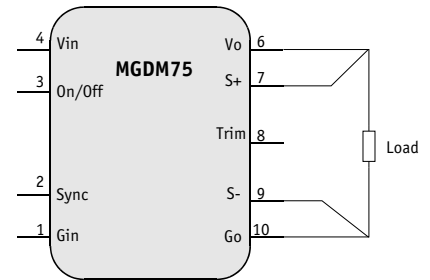

### 12-3 On/Off Function

The control pin 3 (On/Off) can be used for applications requiring On/Off operation. This may be done with an open collector transistor, a switch, a relay or an optocoupler. Several converters may be disabled with a single switch by connecting all On/Off pins together.

- The converter is disabled by pulling low the pin 3.
- No connection or high impedance on pin 4 enables the converter.

By releasing the On/Off function, the converter will restart within the start up time specifications given in table section 3. For further details please consult "Logic On/Off" application note.

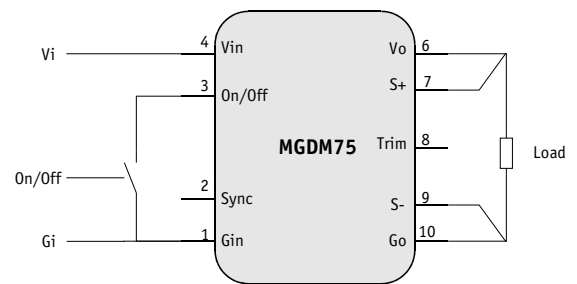

Parameter	Unit	Min.	Typ.	Max.	Notes, conditions
On/Off module enable voltage	Vdc	3.5	/	5	Open, the switch must not sink more than 100µA
On/Off module disable voltage	Vdc	0	/	0.5	The switch must be able to sink 1mA
On/Off alarm level	Vdc	0	/	0.5	OTP or OCP faulty module
On/Off module enable delay	ms	/	/	30	The module restarts with the same delay after alarm mode removed
On/Off module disable delay	µs	/	/	250	Vi nominal, full load

### 12-4 Synchronization Function

An external clock with pulse signals can be used to lock one or more converters (active on rising edge). The external clock signal should have a frequency range from 500KHz to 525KHz, a low level below 0,5V a high level of 4V (+/-0.5V), a rise time of 50 ns max., a fall time of 50ns max., and a pulse width of 300 ns maximum.

Several converters can be synchronized by connecting their Sync pin together.

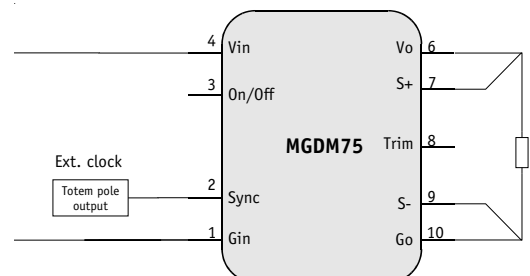
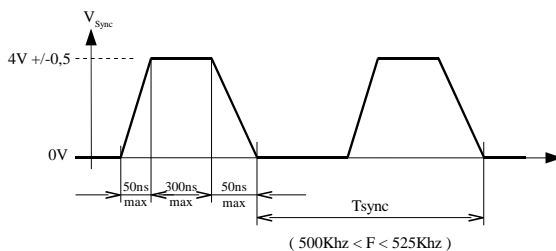

## 13- Application Notes

### 13-1 Caution when Hard Plug-In

Hard plug-in can cause high input voltage or internal overshoot due to resonance of the input filter or internal module filter. This overshoot can lead to internal component voltage breakdown which may damage the converter. In order to avoid such concerns, GAIA Converter recommends to use a minimum of 10µF decoupling capacitor

connected across the Vin and Gin lines of the converter. When designing the EMI input filter, the resonant frequency of this input filter has to be lower than 1 KHz so that when hard plug-in occurs, it will not generate overshoot higher than the maximum input voltage specified. If not, it will be necessary to clamp the overshoot with a transorb.

### 13-2 Input Capacitor Coupling

It is recommended to use a minimum of 10µF decoupling capacitor connected across the Vin and Gin lines of the converter to restore a low line impedance and improve stability

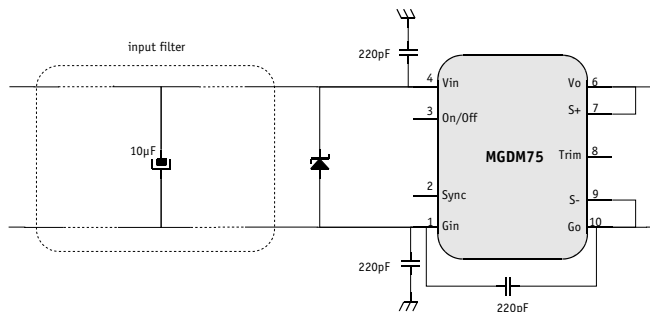

## 13- Application Notes (continued)

### 13-3 Synchronization of Modules

The MGDM-75 high input series provides a synchronization function through the pin 2 (Synchro) to enable automatic synchronization between several converters.

If several converters are used, they lock themselves into the highest switching frequency.

The synchronization signal available on pin 2 is referenced to ground in (Gi).

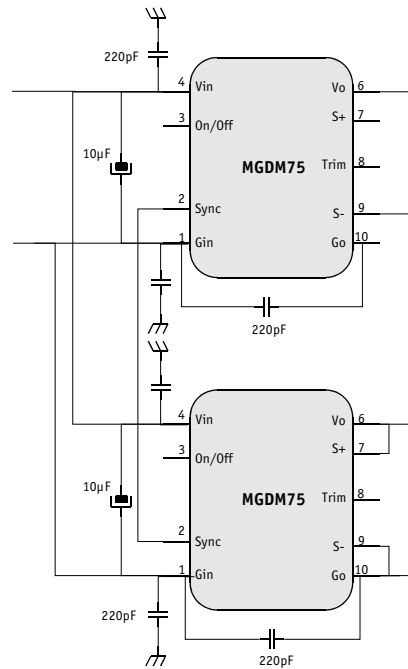

### 13-4 Connection of Modules in Series

The output of single output units can be connected in series without any precautions to provide higher output voltage level.

GAIA Converter recommends to protect each individual output with a Schottky diode rated with the maximum current of the converter to avoid reverse polarity at any output. Reverse polarity may occur at start up if the output voltages are not synchronous.

Special care must be taken to layout properly low level signals Sync. and On/Off from high current tracks. They must be shielded with GIA signal to avoid any disturbances by noises and crosstalk.

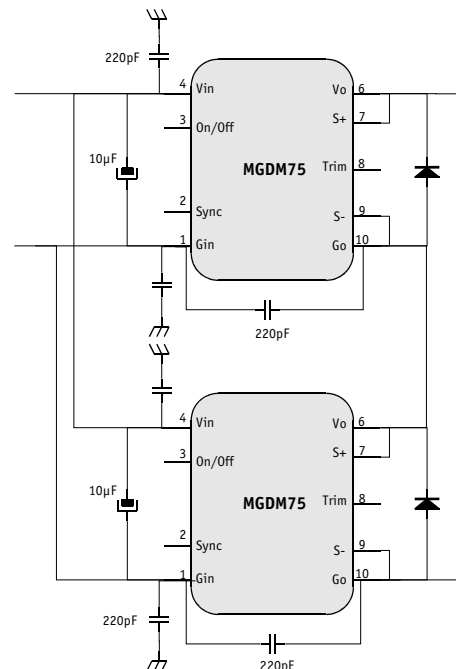

## 11- Dimensions

Dimensions are given in mm (inches). Tolerance : +/- 0,2 mm (+/- 0.01 ") unless otherwise indicated.  
Weight : 60 grams (1.67 Ozs) max.

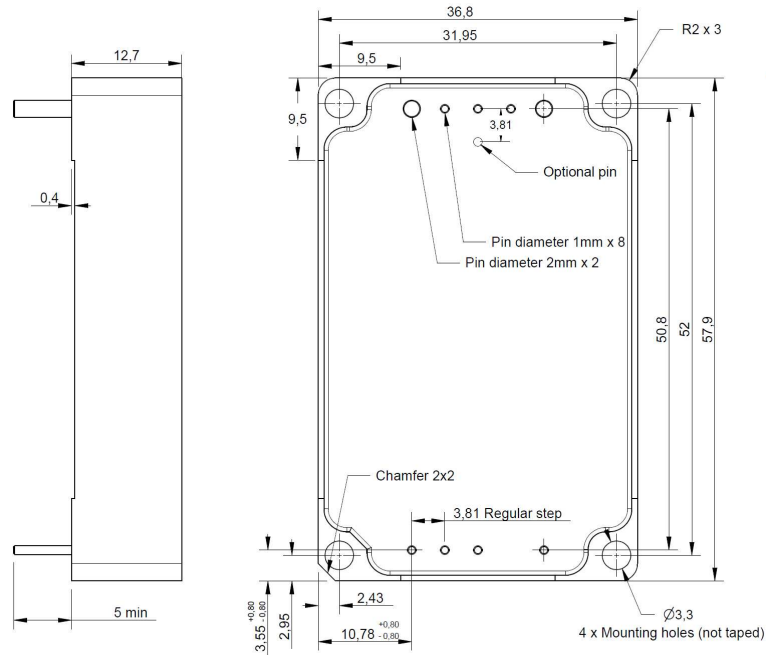

## 12- Materials

Case : Aluminium alodined coating.  
Pins : Plated with flash gold over nickel underplate.

## 13- Product Marking

Side face : Company logo, location of manufacturing.  
: Module reference : MGDx-75-»X»-»Y».  
Date code : year and week of manufacturing, suffix, /option.

## 14- Connections

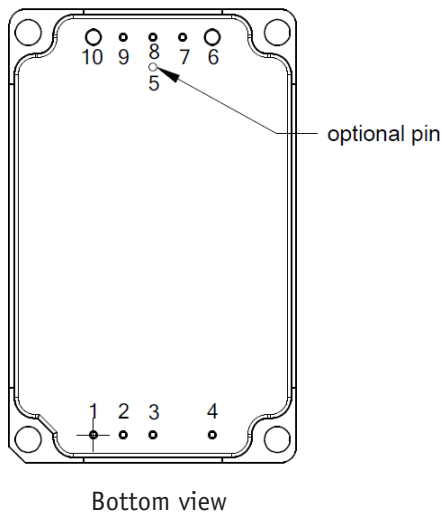

Pin	Single Output
1	- Input (Gi)
2	Synchro (Sync)
3	On/Off
4	+ Input (Vi)
5	No pin
6	+ Output (Vo)
7	Sense + (S+)
8	Trim (Trim)
9	Sense - (S-)
10	- Output (Go)

Pin 5 added with option parallelele referenced /P : «Share»



For more detailed specifications and applications information, contact :

**International Headquarters**

GAIA Converter - France  
ZI de la Morandière  
33185 LE HAILLAN - FRANCE  
Tel. : + (33)-5-57-92-12-80  
Fax : + (33)-5-57-92-12-89

**North American Headquarters**

GAIA Converter Canada, Inc  
4038 Le Corbusier Blvd  
LAVAL, QUEBEC - CANADA H7L 5R2  
Tel. : (514)-333-3169  
Fax : (514)-333-4519

Represented by :