



Hi-Rel DC/DC CONVERTER MGDM-100 : 100W POWER

Hi-Rel
Grade ■ ■

10:1 Ultra Wide Input Single Output Metallic Case - 1.500 VDC Isolation

- 28Vdc input compliant with MIL-STD-1275 for 100Vdc overvoltage transient
- Nominal power up to 100 W
- High efficiency (typ. 88%)
- Soft start
- Galvanic isolation 1.500 VDC
- Integrated LC input filter
- Permanent short circuit protection
- External synchronisation
- External trim and sense adjustment : -20/+10%
- No optocoupler for high reliability
- RoHS process



1-General

The MGDM-100 wide input series is a full family of DC/DC power modules designed for aerospace, military and high-end industrial applications. These modules use a high frequency fixed switching technic at 260KHz providing excellent reliability, low noise characteristics and high power density. Standard models are available with ultra wide input voltage range of 10.7-100 volts covering the entire range of airborne or groundborne requirements. The serie includes single output voltage choices of 3.3, 5, 12, 15 and 24/28 volts. All the modules are designed with LC network filters to minimize reflected input current ripple and output voltage ripple .

The modules include a soft-start, an input undervoltage and overvoltage lock-out, a permanent short circuit protection and an output overvoltage protection to ensure efficient module protections. The soft-start allows current limitation and eliminates inrush current during start-up. The short circuit protection completely protects the modules against short-circuits of any duration by a shut-down and restores to normal when the overload is removed. The design has been carried out with surface mount components and is manufactured in a fully automated process to guarantee high quality. Each module is tested with a GAIA Converter automated test equipment.

4

2-Product Selection

MGDS - 100 - - /

Input Voltage Range

Permanent	Transient
M : 10.7-100 VDC*	n/a

* Some models are limited to 10.7-60 VDC permanent input range

Output

- B : 3.3 VDC
 - C : 5 VDC
 - E : 12 VDC
 - F : 15 VDC
 - 26 : 26 VDC (for 24/28 VDC application)
- For lower output voltage below 3.3V please consult factory

Options :

- /T : option for -55°C start up operating temperature
- /S : option for screening and serialization

2- Product Selection (continued)

Input range	Output	Current	Reference	Options
10.7-100 VDC	3,3 VDC	20 A	MGDS-100-M-B	/T, /S
10.7-100 VDC	5 VDC	20 A	MGDS-100-M-C	/T, /S
10.7-100 VDC	12 VDC	8,25 A	MGDS-100-M-E	/T, /S
10.7-100 VDC*	15 VDC	6,5 A	MGDS-100-M-F*	/T, /S
10.7-100 VDC*	26 VDC	3,8 A	MGDS-100-M-26*	/T, /S

Note * : The MGDS-100-M-F and MGDS-100-M-26 have a permanent input range of 10.7 to 60 VDC and can sustain transient up to 100VDC/0.1sec..

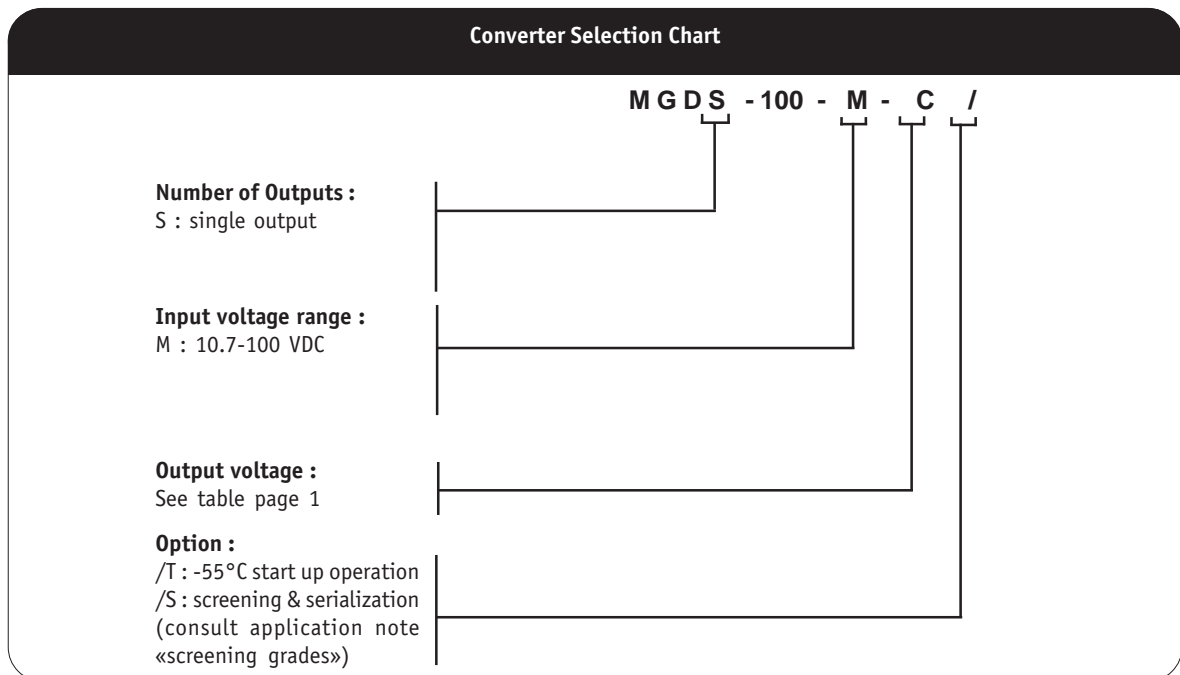

3- Electrical Specifications

Data are valid at +25°C, unless otherwise specified.

Parameter	Conditions	Limit or typical	Units	MGDS-100-M Single Output
Input				
Nominal input voltage	Full temperature range	Nominal	VDC	28
Permanent input voltage for 3,3V to 12V output models for 15, 26V output models	Full temperature range	Min. - Max.	VDC	10.7-100
		Min. - Max.	VDC	10.7-60
Transient input voltage for 15V, 26V output models	Full load Full temperature range	Maximum	VDC/S	100 / 0.1
Undervoltage lock-out (UVLO)	Turn-on voltage	Nominal	VDC	10.5
	Turn-off voltage	Nominal	VDC	9.5
Overvoltage lock-out (OVLO)	Turn-on voltage	Nominal	VDC	98
	Turn-off voltage	Nominal	VDC	104
Start up time	Ui nominal within 3 ms Nominal output Full load : resistive	Maximum	ms	30
Reflected ripple current	Ui nominal, full load at switching freq. BW = 20MHz	Maximum	mApp	TBD
No load input power	Ui min. to max. No load	Maximum	W	for VO<=12Vdc : 10W for VO>12Vdc : 2W
Standby input power	Ui min. to max. No load	Maximum	W	1
Output				
Output voltage *	Ui min. to max.	Nominal	VDC	3,3
		Nominal	VDC	5
		Nominal	VDC	12
		Nominal	VDC	15
		Nominal	VDC	26
Set Point accuracy *	Ambient temperature : +25°C Ui nominal, 75% load	Maximum	%	+/- 2
Output power **	Full temperature range Ui min. to max.	Maximum	W	see curves section 10
Output current ** 3,3V and 5V output 12V output 15V output 26V output	Full temperature range Ui min. to max.	Maximum	A	20
		Maximum	A	8,25
		Maximum	A	6,5
		Maximum	A	4
Ripple output voltage *** 3,3V and 5V output 12V output 15V output 26V output	Ui nominal Full load BW = 20MHz	Maximum	mVpp	50
		Maximum	mVpp	100
		Maximum	mVpp	150
		Maximum	mVpp	250
Output regulation*&**** (Line + load + thermal)	Ui min. to max. 0% to full load	Maximum	%	+/- 1
output Voltage Trim	As a function of output voltage	Minimum	%	80
		Maximum	%	110
Efficiency	Ui nominal Full load	Typical	%	88

Note *: These performances are measured with the sense line connected.

Note **: It is recommended to mount the converter on a heatsink for this test, see section 10 for further details.

Note ***: The ripple output voltage is the periodic AC component imposed on the output voltage, an aperiodic and random component (noise) has also to be considered. This noise can be reduced by adding 1 external decoupling capacitor connected between Gin and Gout. These capacitance should be layed-out as close as possible from the converter. The ripple output voltage is measured by connecting a ceramic chip capacitor Co across Vo and Go pins (C=100µF if Vo<=5Vdc C=10µF if Vo>5Vdc)

Note ****: For 3.3V output model, from 70V to 100V, a minimum load of 2W is required otherwise the converter falls in hiccup mode.

4- Electrical Characteristics (continued)

Fig 1 : Typical efficiency MGDS-100-M-B at 25°C

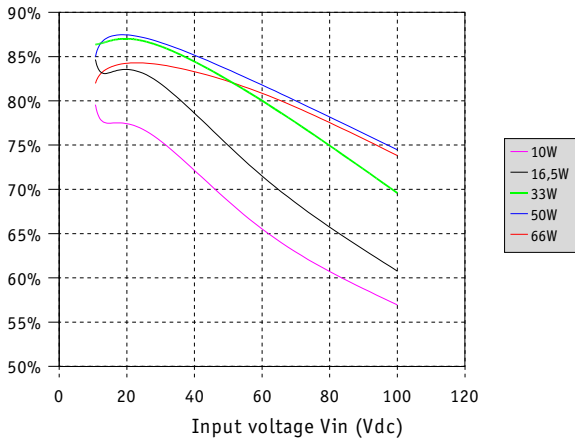

Fig 2 : Typical efficiency MGDS-100-M-C at 25°C

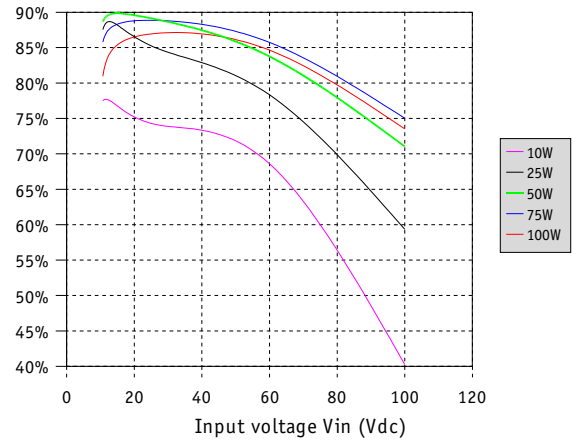

Fig 3 : Typical efficiency MGDS-100-M-E at 25°C

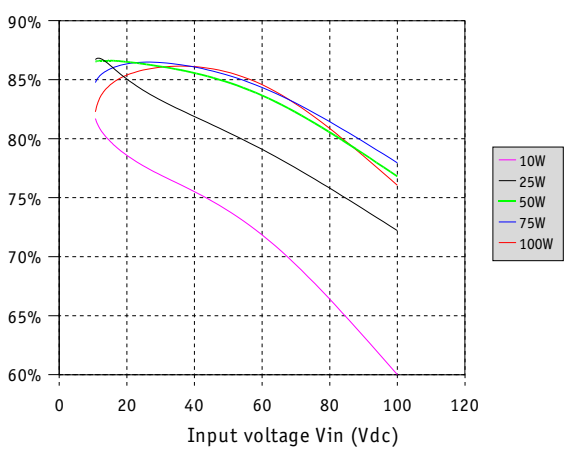

Fig 4 : Typical efficiency MGDS-100-M-F at 25°C

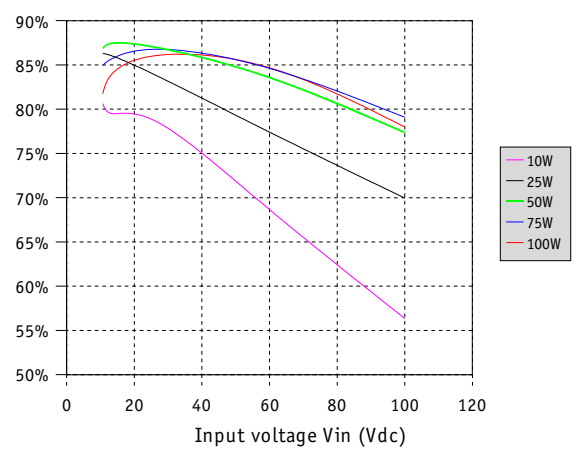
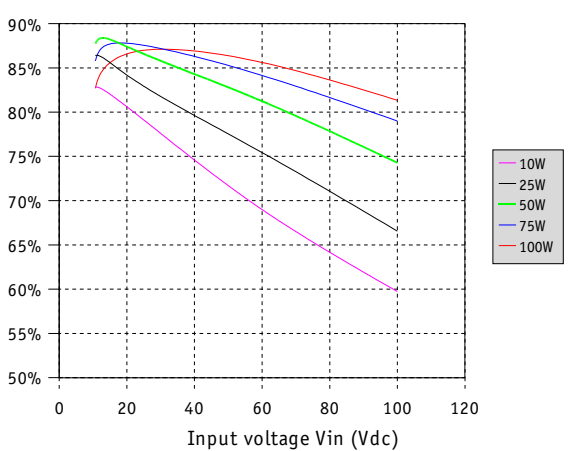

Fig 5 : Typical efficiency MGDS-100-M-26 at 25°C



4- Switching Frequency

Parameter	Conditions	Limit or typical	Specifications
Switching frequency	Full temperature range Ui min. to max. No load to full load	Nominal, fixed	260 KHz

5- Isolation

Parameter	Conditions	Limit or typical	Specifications
Electric strength test voltage "M" input range	Input to output	Minimum	1.500 VDC / 1 min
Isolation resistance	Input to case Output to case	Minimum Minimum	100 MOhm 100 MOhm

6- Protection Functions

Characteristics	Protection Device	Recovery	Limit or typical	Specifications
Input undervoltage lock-out (UVLO)	Turn-on, turn-off circuit with hysteresis cycle	Automatic recovery	Turn-on nominal Turn-off nominal	See section 3
Input overvoltage lock-out (OVLO)	Turn-on, turn-off circuit with hysteresis cycle	Automatic recovery	Turn-on nominal Turn-off nominal	See section 3
Output current limitation protection (OCP)	Straight line current limitation	Automatic recovery	Nominal	130%
Output overvoltage protection (OVP)	Overvoltage protection limitation	Automatic recovery	Min. - max.	120% +/-5% of output voltage
Over temperature protection (OTP)	Thermal device with hysteresis cycle	Automatic recovery	Nominal	115°C

7- Reliability Data

Characteristics	Conditions	Temperature	Specifications
Mean Time Between Failure (MTBF) According to MIL-HDBK-217F	Ground fixed (Gf)	Case at 40°C Case at 85°C	600.000 Hrs 210.000 Hrs
	Airborne, Inhabited, Cargo (AIC)	Case at 40°C Case at 85°C	330.000 Hrs 125.000 Hrs
Mean Time Between Failure (MTBF) According to IEC-62380-TR	Avionics Military Cargo	/	Consult factory

8- Electromagnetic Interference

Electromagnetic Interference requirements according to MIL-STD-461C/D/E standards can be easily achieved as indicated in the following section. The following table resumes the different sections covered by these standards.

Standard Requirements	MIL-STD-461C Standard	MIL-STD-461D/E Standard	Compliance with GAIA Converter Module & common mode capacitance
Conducted emission (CE) : Low frequency High frequency	CE 01 CE 03	CE 101 CE 102	compliant module stand-alone compliant with additional filter
Conducted susceptibility (CS) : Low frequency High frequency	CS 01 CS 02	CS 101 CS114	compliant with additional filter compliant with additional filter
Radiated emission (RE) : Magnetic field Electrical field	RE 01 RE 02	RE 101 RE 102	compliant module stand-alone compliant module stand-alone
Radiated susceptibility (RS) : Magnetic field Electrical field	RS 01 RS 03	RS 101 RS 103	compliant module stand-alone compliant module stand-alone

8-1 Module Compliance with MIL-STD-461C/D/E Standards

To meet the latest US military standards MIL-STD-461D/E (and also the MIL-STD-461C) requirements and in particular the conducted noise emission CE102 (and also CE03) requirements, Gaia Converter can propose a stand-alone ready-to-use EMI filter module. This EMI filter module has to be used together with 4 external decoupling capacitance C_c (10nF/rated voltage depending on isolation requirement) connected between input and case and output and case.

EMI filter module reference : FGDS-10A-50V or FGDS-20A-50V.
Please consult EMI filter datasheet for further details.

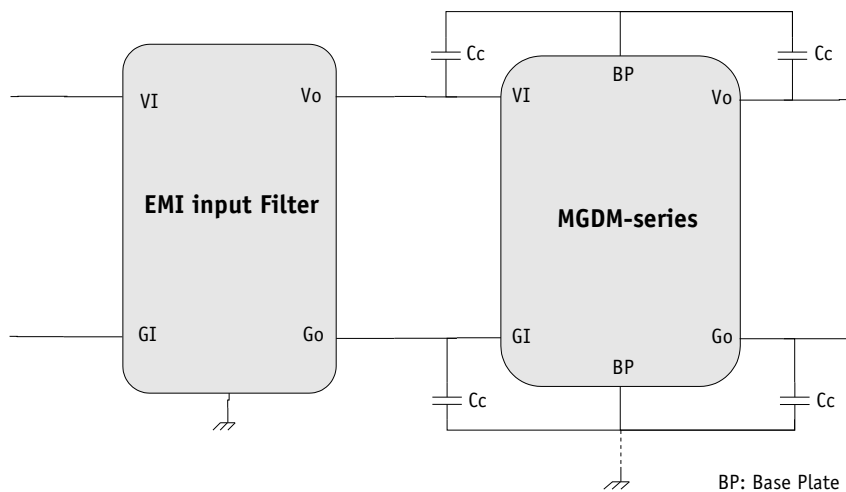

10- Thermal Characteristics

Characteristics	Conditions	Limit or typical	Performances
Operating ambient temperature range	Ambient temperature	Minimum Maximum	-40°C see curve
Operating case temperature range at full load	Case temperature	Minimum Maximum	- 40°C see curve below
Storage temperature range	Non functioning	Minimum Maximum	- 40°C + 115°C
Thermal resistance	Rth case to ambient in free air natural convection	Typical	6°C /W

The MGDM-100 series maximum **baseplate** temperature must not exceed following values and is a function of output load as described in the following figures :

MGDM-100 Series Maximum Baseplate Temperature Versus Output Power

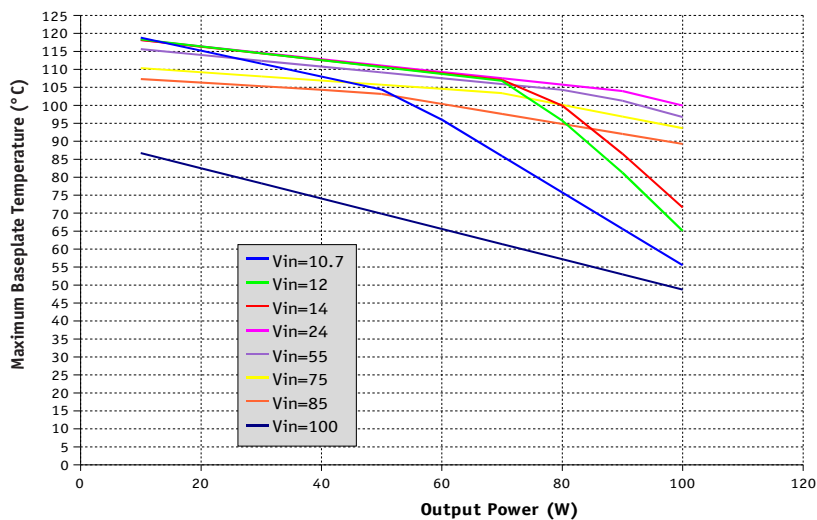

Heat can be removed from the baseplate via three basic mechanisms :

- Radiation transfert : radiation is counting for less than 5% of total heat transfert in majority of case, for this reason the presence of radiant cooling is used as a safety margin and is not considered.
- Conduction transfert : in most of the applications, heat will be conducted from the baseplate into an attached heatsink or heat conducting member; heat is conducted thru the interface.
- Convection transfert : convecting heat transfer into air refers to still air or forced air cooling.

In majority of the applications, heat will be removed from the baseplate either with :

- heatsink,
- forced air cooling,
- both heatsink and forced air cooling.

To calculate a maximum admissible ambient temperature the following method can be used.

Knowing the maximum baseplate temperature $T_{max_baseplate}$ of the module, the power used P_{out} and the efficiency η :

- determine the power dissipated by the module P_{diss} that should be evacuated :

$$P_{diss} = P_{out}(1/\eta - 1) \quad (A)$$

- determine the maximum ambient temperature :

$$T_a = T_{max_baseplate} - R_{th}(b-a) \times P_{diss} \quad (B)$$

where $R_{th}(b-a)$ is the thermal resistance from the baseplate to ambient.

This thermal $R_{th}(b-a)$ resistance is the summ of :

- the thermal resistance of baseplate to heatsink ($R_{th}(b-h)$). The interface between baseplate and heatsink can be nothing or a conducting member, a thermal compound, a thermal pad.... The value of $R_{th}(b-h)$ can range from 0.4°C/W for no interface down to 0.1°C/W for a thermal conductive member interface.
- the thermal resistance of heatsink to ambient air ($R_{th}(h-a)$), which is depending of air flow and given by heatsink supplier.

10- Thermal Characteristics (continued)

The table hereafter gives some example of thermal resistance for different heat transfert configurations.

Heat transfert	Thermal resistance heatsink to air Rth(h-a)		Thermal resistance baseplate to heatsink	Global resistance
Free air cooling only	No Heatsink baseplate only :	6°C/W	No need of thermal pad	6°C/W
	Heatsink Aavid Thermalloy 824353B03250	3,9°C/W	Bergquist Silpad* : 0,13°C/W	4,03°C/W
Forced air cooling 200 LFM	No Heatsink baseplate only :	3,8°C/W	No need of thermal pad	3,8°C/W
	Heatsink Aavid Thermalloy 824353B03250	2,1°C/W	Bergquist Silpad* : 0,13°C/W	2,23°C/W
Forced air cooling 400 LFM	No Heatsink baseplate only :	2,63°C/W	No need of thermal pad	2,63°C/W
	Heatsink Aavid Thermalloy 824353B03250	1,5°C/W	Bergquist Silpad* : 0,13°C/W	1,63°C/W
Forced air cooling 1000 LFM	No Heatsink baseplate only :	1,54°C/W	No need of thermal pad	1,54°C/W
	Heatsink Aavid Thermalloy 824353B03250	1°C/W	Bergquist Silpad* : 0,13°C/W	1,13°C/W

Aavid Thermalloy is a heatsink manufacturers. «Silpad» ® is a registered trademark of Bergquist.
Note* : Silpad performance are for Silpad 400 with pressure conditions of 50 Psi.

The two formulas (A) and (B) described in previous page :

- $P_{diss} = P_{out}(1/\eta - 1)$ (A)
- $T_a = T_{base} - R_{th}(h-a) \times P_{diss}$ (B)

conduct to curves determining the ambient temperature admissible as a function of output power for various heat transfert conditions.

In particular, as example the following typical curves are calculated with :

- no heatsink
- a Aavid Thermalloy heatsink reference 824353B03250 and a Bergquist «Silpad» for various cooling conditions.

4

MGDM-100 Series Thermal Curves

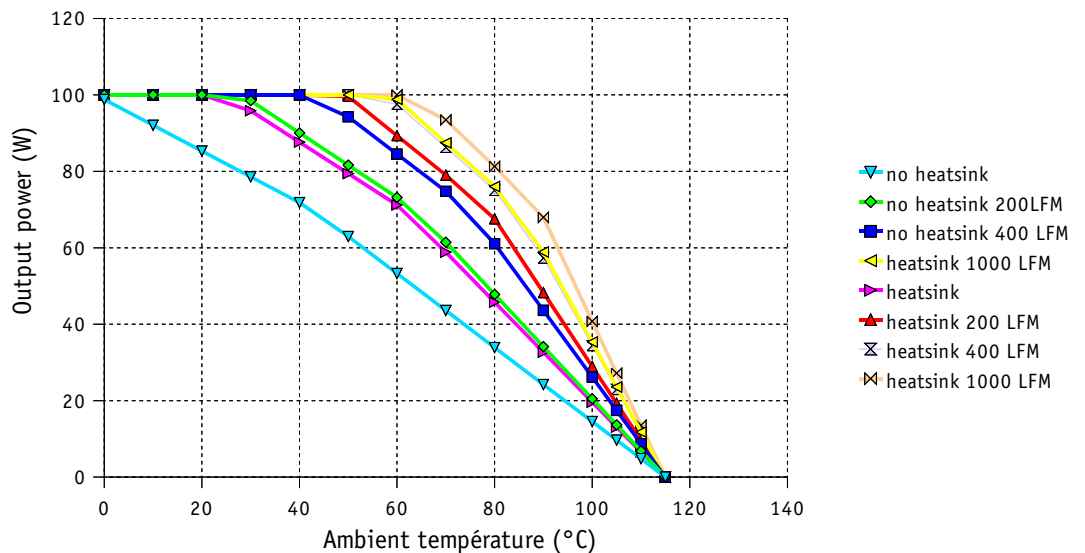

10- Environmental Qualifications

The modules have been subjected to the following environmental qualifications.

Characteristics	Conditions	Severity	Test procedure
Climatic Qualifications			
Life at high temperature	Duration Temperature / status of unit	Test D : 1.000 Hrs @ 105°C case, unit operating @ 125°C ambient, unit not operating	MIL-STD-202G Method 108A
Altitude	Altitude level C Duration Climb up Stabilization Status of unit	40.000 ft@-55°C 30 min. 1.000 ft/min to 70.000 f@-55°C, 30 min. unit operating	MIL-STD-810E Method 500.3
Humidity cyclic	Number of cycle Cycle duration Relative humidity variation Temperature variation Status of unit	10 Cycle I : 24 Hrs 60 % to 88 % 31°C to 41°C unit not operating	MIL-STD-810E Method 507.3
Humidity steady	Damp heat Temperature Duration Status of unit	93 % relative humidity 40°C 56 days unit not operating	MIL-STD-202G Method 103B
Salt atmosphere	Temperature Concentration NaCl Duration Status of unit	35°C 5 % 48 Hrs unit not operating	MIL-STD-810E Method 509.3
Temperature cycling	Number of cycles Temperature change Transfert time Steady state time Status of unit	200 -40°C / +85°C 40 min. 20 min. unit operating	MIL-STD-202A Method 102A
Temperature shock	Number of shocks Temperature change Transfert time Steady state time Status of unit	100 -55°C / +105°C 10 sec. 20 min. unit not operating	MIL-STD-202G Method 107G
Mechanical Qualifications			
Vibration (Sinusoidal)	Number of cycles Frequency / amplitude Frequency / acceleration Duration Status of unit	10 cycles in each axis 10 to 60 Hz / 0.7 mm 60 to 2000 Hz / 10 g 2h 30 min. per axis unit not operating	MIL-STD-810D Method 514.3
Shock (Half sinus)	Number of shocks Peak acceleration Duration Shock form Status of unit	3 shocks in each axis 100 g 6 ms 1/2 sinusoidal unit not operating	MIL-STD-810D Method 516.3
Bump (Half sinus)	Number of bumps Peak acceleration Duration Status of unit	2000 Bumps in each axis 40 g 6 ms unit not operating	MIL-STD-810D Method 516.3

12- Description of Protections

The MGDM-100 series include 5 types of protection devices.

12-1 Input Undervoltage Lockout (UVLO) and Overvoltage Lockout (OVLO)

12-1-1 Undervoltage Lockout (UVLO)

An input undervoltage protection will inhibit the module when input voltage drops below the lock-out turn-off threshold (see section 3 for value) and restores to normal operation automatically when the input voltage rises the lock-out turn-on threshold.

The input undervoltage lock-out threshold (UVLO) can be trimmed by connecting a resistor between UVLO and Gi pins. This resistance can be calculated as follow :

$$R_{UVLO} = \frac{a \times (1 + b - n)}{(n - 1)} \quad \text{where } n = \frac{UVLO_{trim}}{UVLO_{threshold}}$$

Input M	
a	1000
b	13.2

12-1-2 Overvoltage Lockout (OVLO)

An input overvoltage protection will inhibit the module when input voltage reaches the overvoltage lockout turn-off threshold (see section 3 for value) and restores to normal operation automatically when the input voltage drops below the overvoltage Lockout turn on threshold.

12-2 Output Over Current Protection (OCP)

The MGDM-100 Series incorporates a straight line current limit and protection circuit. When the output current reaches 130% of it's full-rated current ($I_{current \ limit}$), the output voltage decreases down to 75% of nominal output voltage. Below this threshold the converter falls in hiccup mode by testing periodically if an overload is applied. The module restart automatically to normal operation when overcurrent is removed.

12-3 Output Overvoltage Protection (OVP)

The MGDM-100 series has an internal overvoltage protection circuit that monitors the voltage across the output power terminals. It is designed to limit the converter at 120% (+/-5%) of output voltage.

12-4 Over Temperature Protection (OTP)

A thermal protection device adjusted at 115°C (+/-5%) internal temperature with 10°C hysteresis cycle will inhibit the module as long as the overheat is present and restores to normal operation automatically when overheat is removed. The efficiency of the OTP function is warranty with the module mounted on a heatsink.

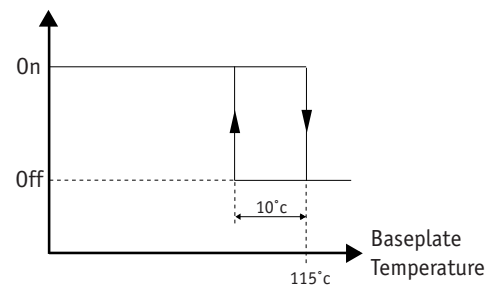
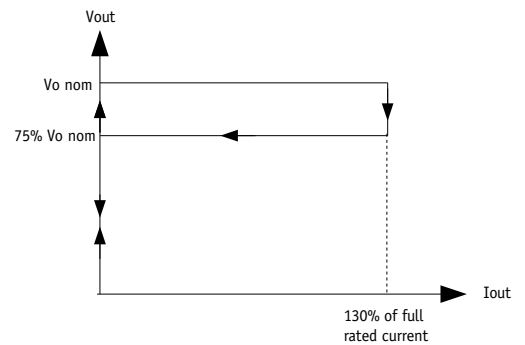
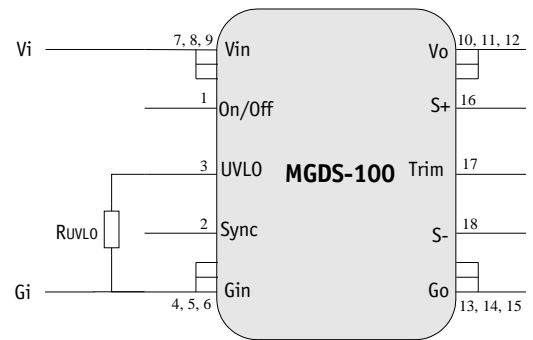
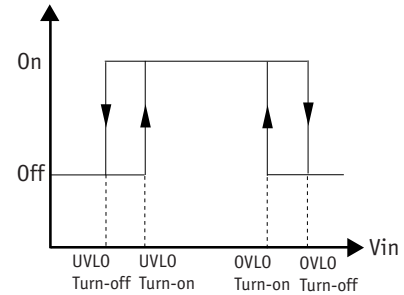

13- Description of Functions

13-1 Trim Function

The output voltage V_o may be trimmed in a range of 80%/110% of the nominal output voltage via a single external trimpot or fixed resistor.

Trim Up Function

Do not attempt to trim the module higher than 110% of nominal output voltage as the overvoltage protection may occur.

Also do not exceed the maximum rated output power when the module is trimmed up.

The trim up resistor must be connected to S+ pin.

The trim up resistance must be calculated with the following formula :

$$R_u = \frac{R_1 (V_o - V_{ref}) V_{o_{nom}}}{(V_o - V_{o_{nom}}) V_{ref}} - R_1 - R_2$$

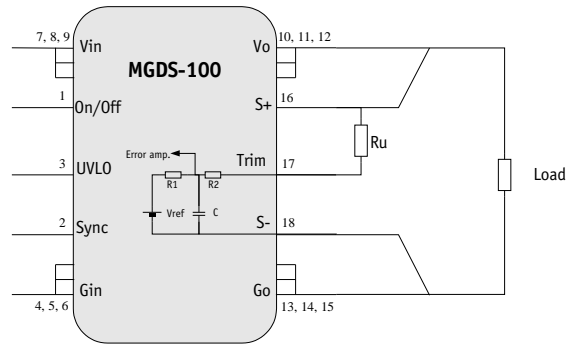

Trim Down Function

Do not trim down more than -20% of nominal output voltage otherwise the module may turn off.

The available output power is reduced by the same percentage that output voltage is trimmed down.

The trim down resistor must be connected to S- pin.

The trim down resistance must be calculated with the following formula :

$$R_d = \frac{(R_2 + R_1) V_o - R_2 V_{o_{nom}}}{V_{o_{nom}} - V_o}$$

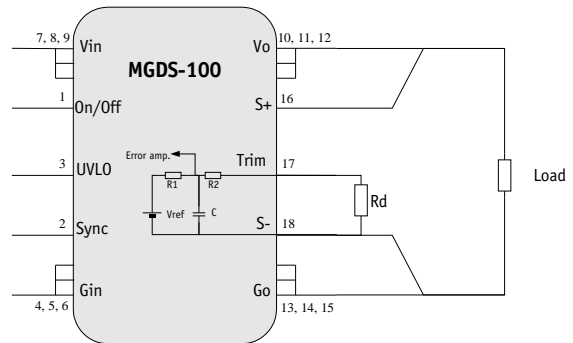

Trim via a voltage

The output voltage is given by the following formula :

$$V_o = \left(1 + \frac{R_1}{R_1 + R_2} \right) \frac{V_{cont}}{V_{ref}} \times V_{nom}$$

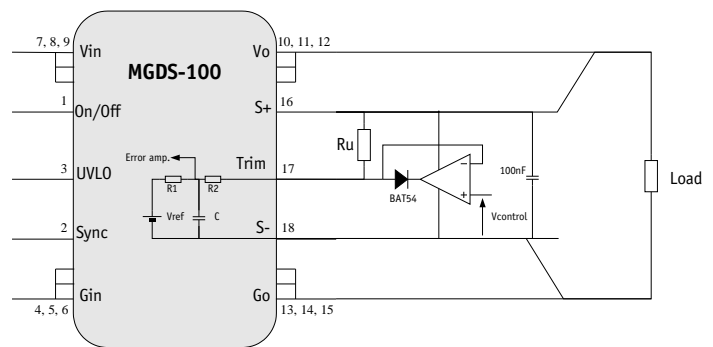

Parameter	Unit	Min.	Typ.	Max.
Trim reference	Vdc	2,45	2,5	2,55
Resistor R1	Ohm	/	39K	/
Resistor R2	Ohm	/	270	/
Trim capacitor C	nF	/	10	/

13- Description of Functions (continued)

13-2 Sense Function

If the load is separated from the output by any line length, some of these performance characteristics will be degraded at the load terminals by an amount proportional to the impedance of the load leads. Sense connections enable to compensate the line drop at a maximum of 10% of output voltage. The overvoltage protection will be activated if remote sense tries to boost output voltage above 120% of nominal output voltage. Connection is described in figure herein.

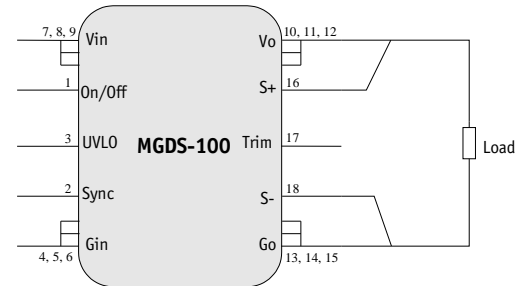

13-3 On/Off Function

The control pin 1 (On/Off) can be used for applications requiring On/Off operation. This may be done with an open collector transistor, a switch, a relay or an optocoupler. Several converters may be disabled with a single switch by connecting all On/Off pins together.

- The converter is disabled by pulling low the pin 1.
- No connection or high impedance on pin 1 enables the converter.

By releasing the On/Off function, the converter will restart within the start up time specifications given in table section 3

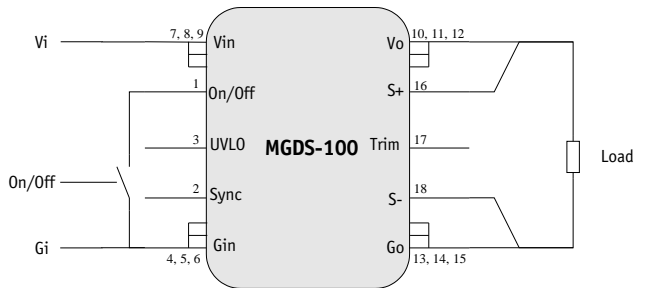

Parameter	Unit	Min.	Typ.	Max.	Notes, conditions
On/Off module enable voltage	Vdc	3.5	/	5	Open, the switch must not sink more than 100µA
On/Off module disable voltage	Vdc	0	/	0.5	The switch must be able to sink 1mA
On/Off alarm level	Vdc	0	/	0.5	OTP faulty module
On/Off module enable delay	ms	/	/	30	The module restarts with the same delay after alarm mode removed
On/Off module disable delay	µs	/	/	100	Vi nominal, full load

13-4 Synchronization Function

An external clock with pulse signals can be used to lock one or more converters (active on rising edge). The external clock signal should have a frequency range from 270KHz to 300KHz, a low level below 0,5V a high level of 4V (+/-0.5V), a rise time of 30 ns max., a fall time of 100ns max., and a pulse width of 300 to 500 ns.

Several converters can be synchronized by connecting their Sync pin together.

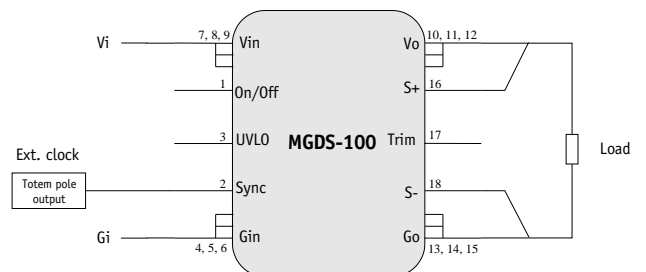
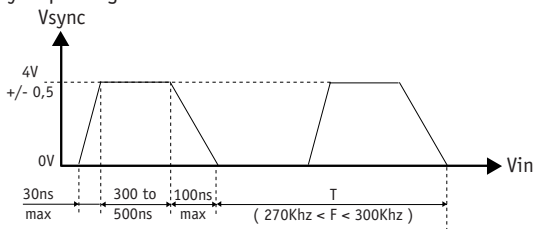

14- Application Notes

14-1 Input to Output Impedance

The MGDM-100 converters have been designed to be stable with no external capacitors when used in low inductance input and output circuits.

However, in many applications, the inductance associated with the distribution from the power source to the input of the converter can affect the stability of the converter. The addition of a $C_{in}=100\mu F$ electrolytic capacitor with an $ESR < 1$ across the input helps ensure stability of the converter.

In many applications, the user has also to use decoupling capacitance at the load. The addition of a decoupling ceramic chip capacitor C_o ($C_o=10\mu F$ if $V_o>5Vdc$ or $C_o=100\mu F$ if $V_o \leq 5Vdc$) across the output and placed close to the converter allows to achieve the output voltage ripple specified in the table page 3.

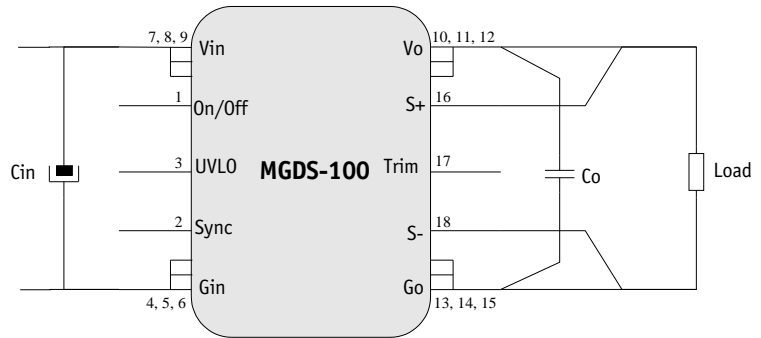

14-2 Synchronization of Modules

The MGDM-100 series provides a synchronization function through the pin 2 (Synchro) to enable automatic synchronization between several converters.

If several converters are used, they lock themselves into the highest switching frequency.

The synchronization signal available on pin 2 is referenced to ground in (Gi).

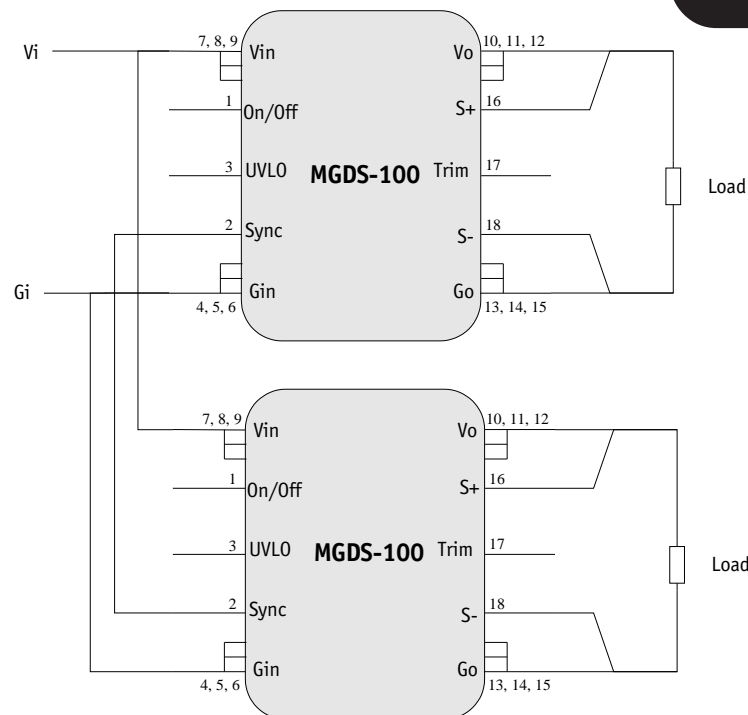

14-3 Connection of Modules in Series

The output of single output units can be connected in series without any precautions to provide higher output voltage level. Nevertheless, GAIA Converter recommends to protect each individual output by a low power shottky diode rated with the maximum current of the converter to avoid reverse polarity at any output. Reverse polarity may occur at start up if the output voltages do not rise at the same time.

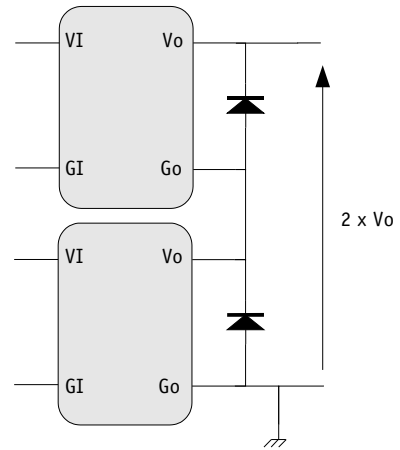

15- PCB Mounting Specifications

The MGDM-100 series has been designed for low profile applications. Two levels of mounting can be designed :

- On-board mounting with 12,5 mm height
- In-board mounting with 10,5 mm height and PCB hole design on the mother board

On-board Mounting



In-board Mounting



16- Dimensions

Dimension are given in mm (inches). Tolerance : +/- 0,2 mm (+/- 0.01 ") unless otherwise indicated.
Weight : 65 grams (2.30 Ozs) max.

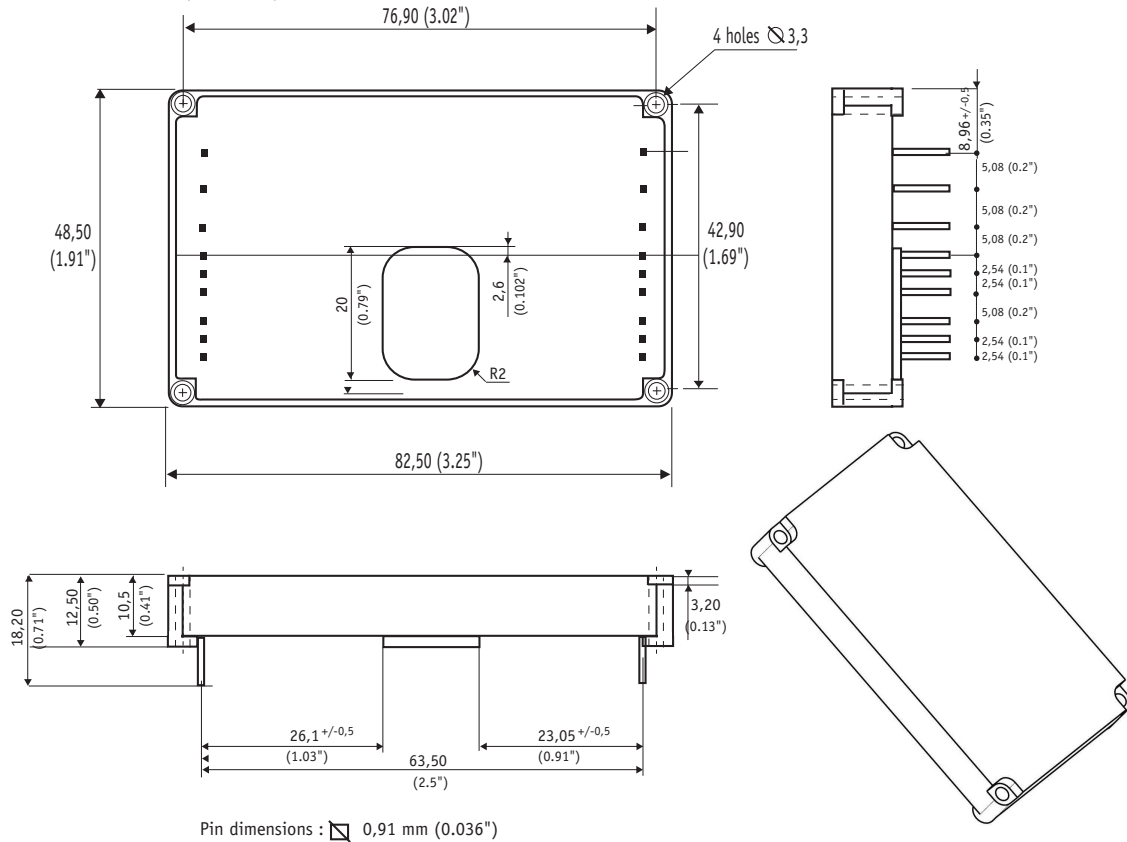

17- Materials

Case : Metallic black anodized coating.
Pins : Plated with pure matte tin over nickel underplate.

18- Product Marking

Upper face : Company logo, location of manufacturing.
Side face : Module reference, option, date code : year and week of manufacturing.

19- Connections

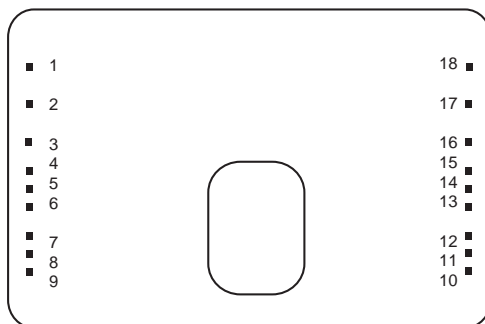

Bottom view

Pin	Single
1	On / Off
2	Syncro (Sync)
3	UVLO
4, 5, 6	- Input (Gi)
7, 8, 9	+ Input (Vi)
10, 11, 12	Output (Vo)
13, 14, 15	Common (Go)
16	Sense +
17	Trim
18	Sense -



For more detailed specifications and applications information, contact :

International Headquarters

GAIA Converter - France
ZI de la Morandière
33185 LE HAILLAN - FRANCE
Tel. : + (33)-5-57-92-12-80
Fax : + (33)-5-57-92-12-89

North American Headquarters

GAIA Converter Canada, Inc
4038 Le Corbusier Blvd
LAVAL, QUEBEC - CANADA H7L 5R2
Tel. : (514)-333-3169
Fax : (514)-333-4519

Represented by :